

COALBURN MEDIA CONSOLE

ASSEMBLY INSTRUCTIONS



PARTS AND FITTING PACKAGING DETAIL

BOX#1

A. BODY 1PC

B. STAND 1PC

C. WHEEL BRACKET 2PCS

D. WHEELS 2PCS

E. HANDLE 1PC

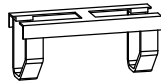
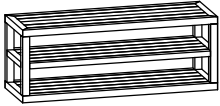

BRACKET

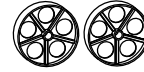

COALBURN MEDIA CONSOLE ASSEMBLED

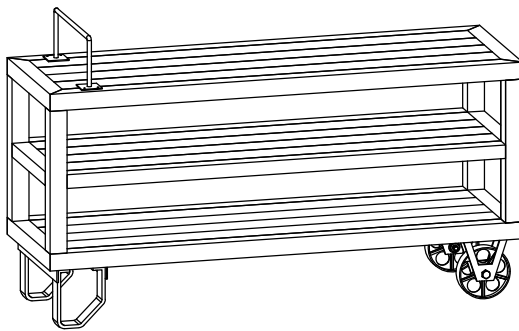

HARDWARE * PACKED IN BOX #1

H1	BOLT M8 X 30mm	16 PCS	H2	WHEEL AXEL Ø25 X 80mm	2 PCS
H3	FLAT WASHER M8	2 PCS	H4	NUT Ø14 X 6mm	2 PCS
H5	HEX WRENCH 23mm	1 PC	H6	ALLEN KEY M4	1 PCS

YOUR BOX MAY CONTAIN EXTRA HARDWARE

STEP 1

Following the illustration, attach the Stand (B) to the bottom of the Body (A) with four Bolts (H1). Tighten completely with provided Allen Key (H6).
NOTE! Stand can be installed on either side of the Body.

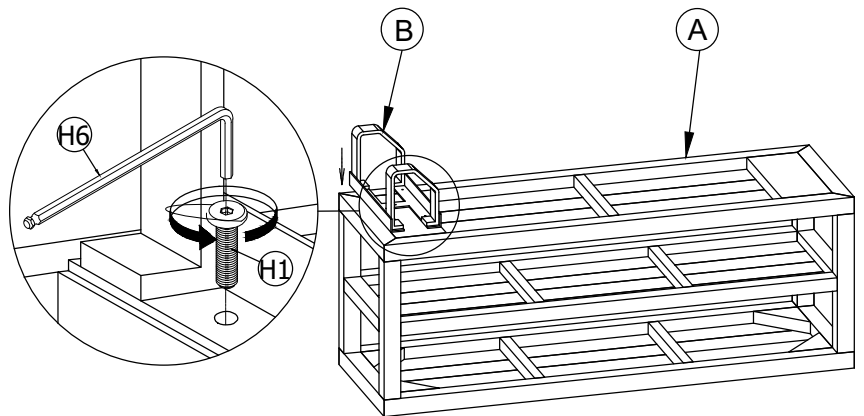

STEP 2

Attach one Wheel Bracket (C) to the Body with two Bolts. Tighten completely. Repeat for second Wheel Bracket.

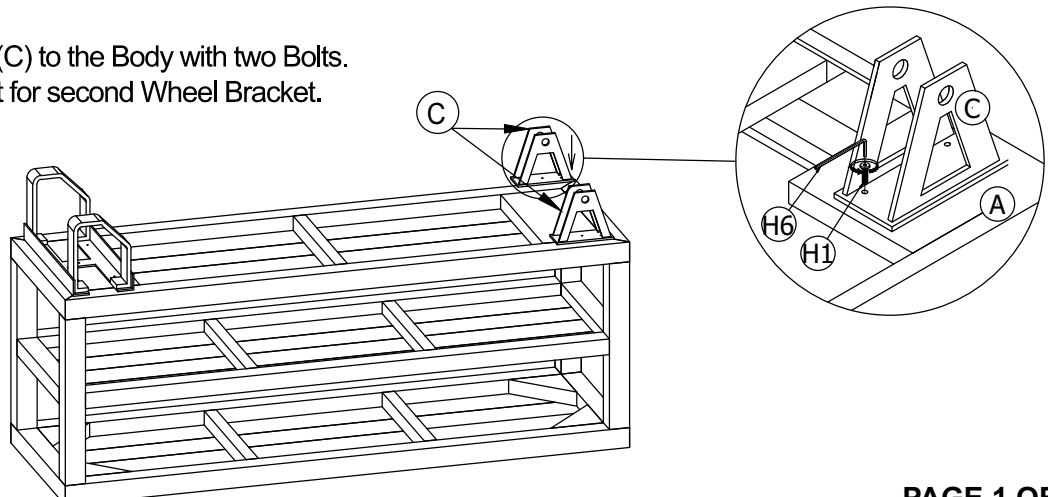

COALBURN MEDIA CONSOLE

ASSEMBLY INSTRUCTIONS



STEP 3

Attach Wheels (D) to Wheel Brackets (C) using Wheel Axels (H2), Washers (H3) and Nuts (H4). Tighten each Nut with Hex Wrench (H5).

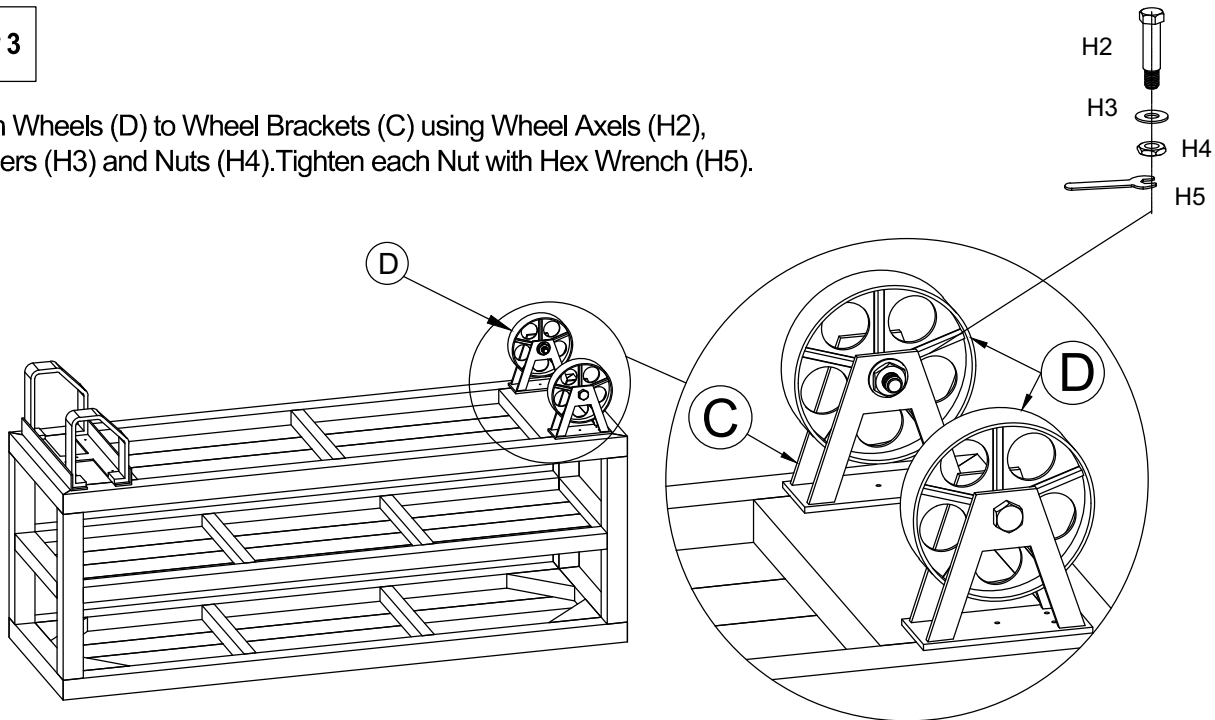

STEP 4

Flip assembled Body right-side up. Attach Handle (E) to the top of the Body with four Bolts. Tighten completely. **NOTE!** The Handle should be installed on the same side as the stand.

