

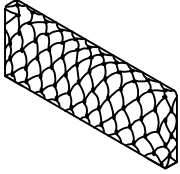

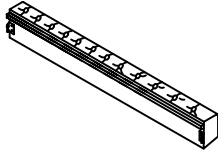

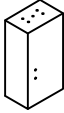

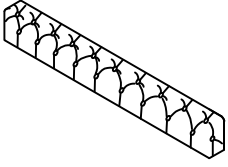

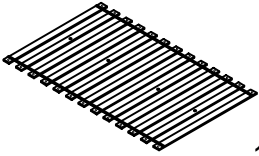
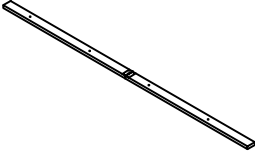
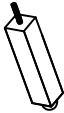

ASSEMBLY INSTRUCTION

5112 Q

<p>(A) HEAD BOARD</p>  <p>1PC</p>	<p>(B) RAIL</p>  <p>2PCS</p>	<p>(C) HB LEG</p>  <p>2PCS</p>	<p>(D) FOOTBOARD</p>  <p>1PC</p>
<p>(E) SLAT</p>  <p>1SET</p>	<p>(F) SUPPORT RAIL</p>  <p>1PC</p>	<p>(G) SUPPORT LEG</p>  <p>4PCS</p>	<p>(H) FB LEG</p>  <p>2PCS</p>
<p>(I) CONNECTION STRAP (L+R)</p>  <p>4PCS</p>	<p>(J) BOLT Ø5/16" x 1"</p>  <p>16PCS</p>	<p>(K) THREADED STUD Ø5/16" x 3-1/8"</p>  <p>8PCS</p>	<p>(L) LOCK WASHER Ø5/16" x Ø12MM</p>  <p>24PCS</p>
<p>(M) FLAT WASHER Ø5/16" x Ø19MM</p>  <p>16PCS</p>	<p>(N) HEX NUT Ø5/16"</p>  <p>8PCS</p>	<p>(O) WOOD TENON Ø10x 40mm</p>  <p>2PCS</p>	<p>(P) SCREW M4 x 38MM</p>  <p>26PCS</p>
<p>(Q) WRENCH 12MM</p>  <p>1PC</p>	<p>(R) ALLEN WRENCH 5MM</p>  <p>1PC</p>	<p>(S) FLAT WASHER Ø5/16" x Ø22MM</p>  <p>8PCS</p>	<p>(T) SCREW M5 x 45MM</p>  <p>2PCS</p>

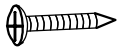
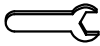
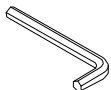
Remark: Parts B in Rail box, All other parts in HB box.

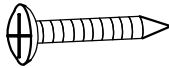
STEP 1

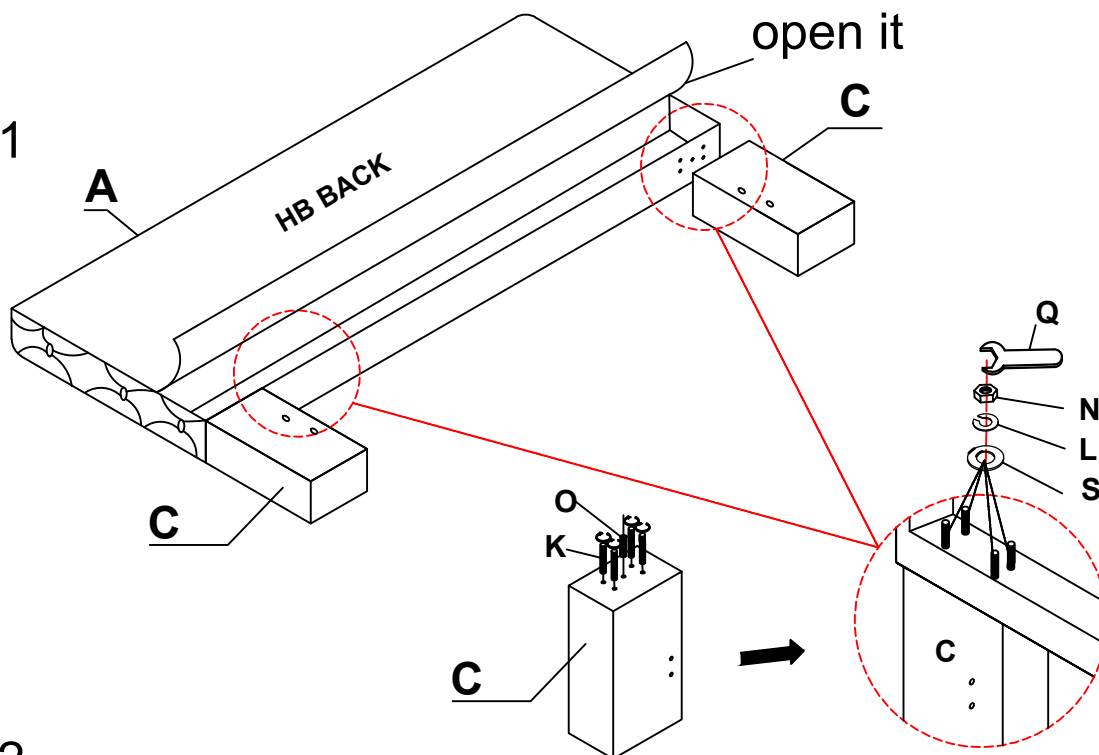

STEP 2

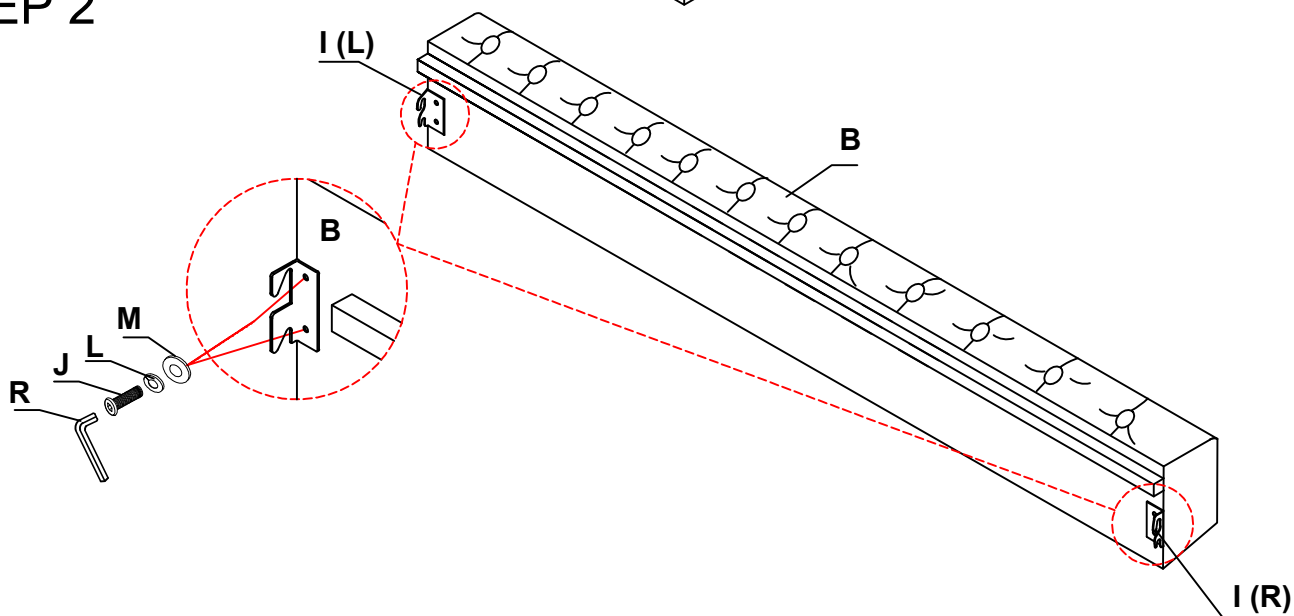

STEP 3

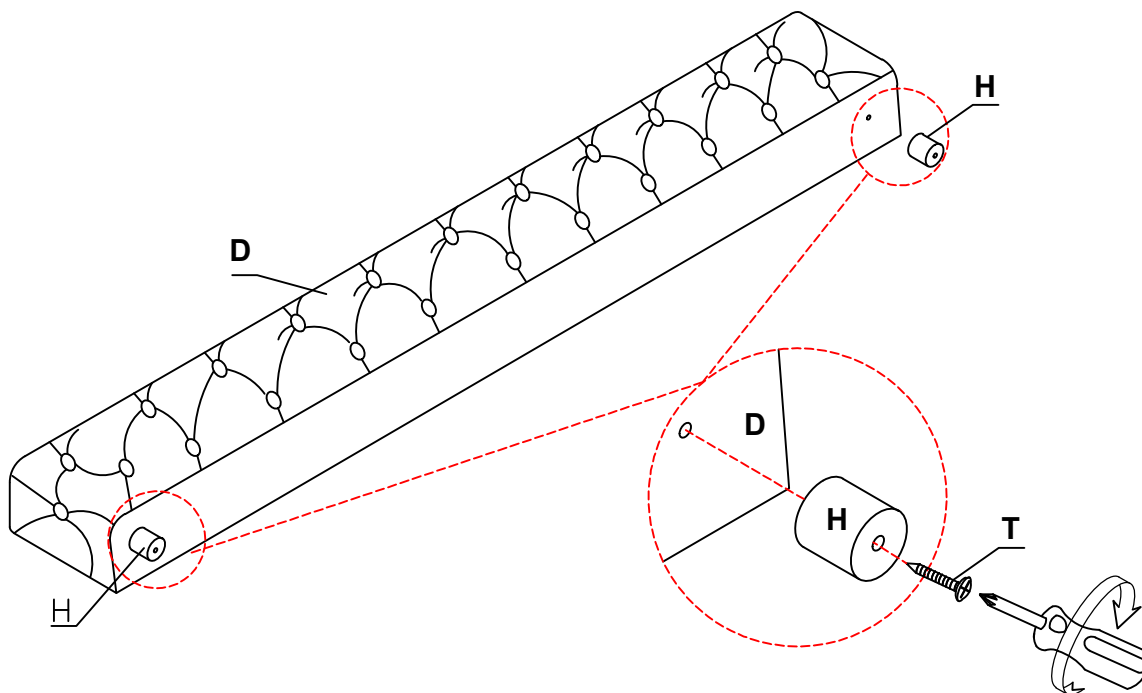

STEP 4

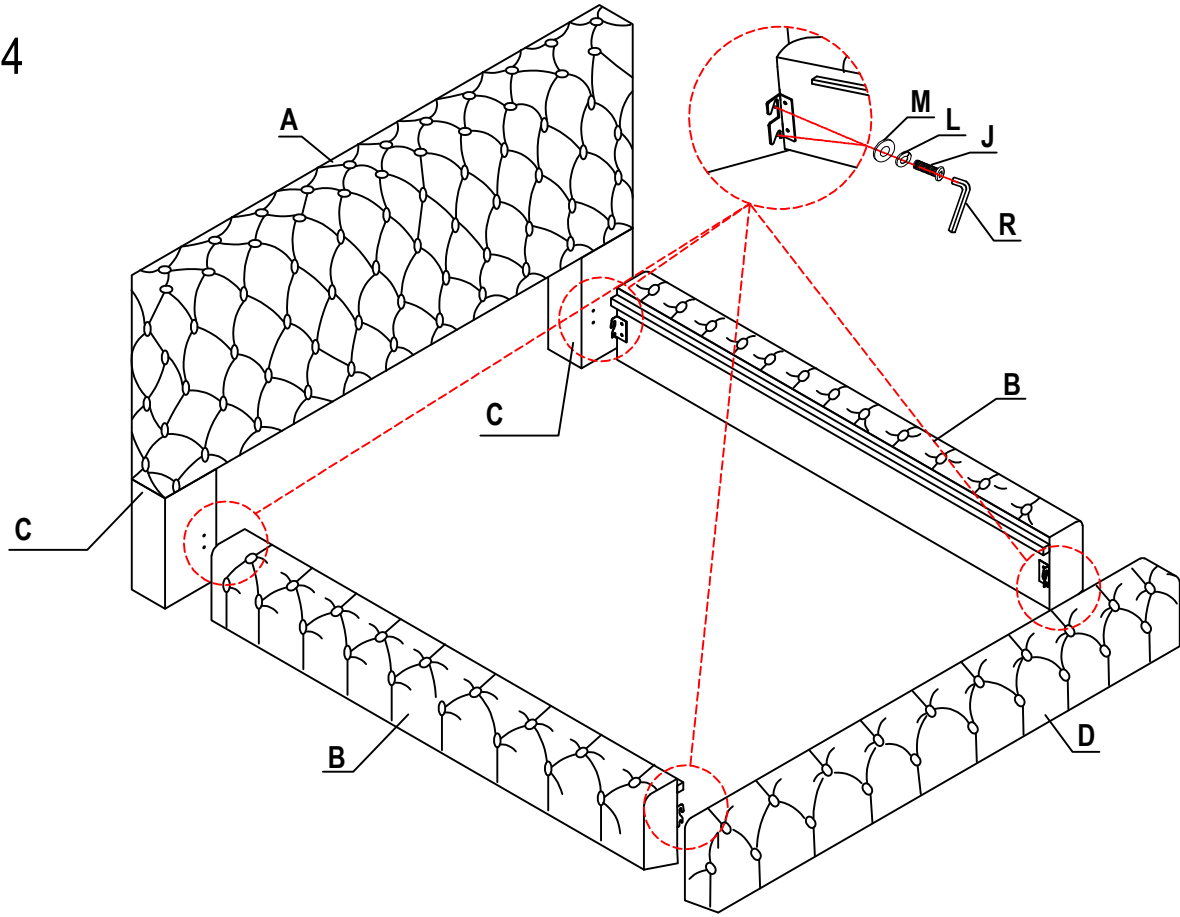

STEP 5

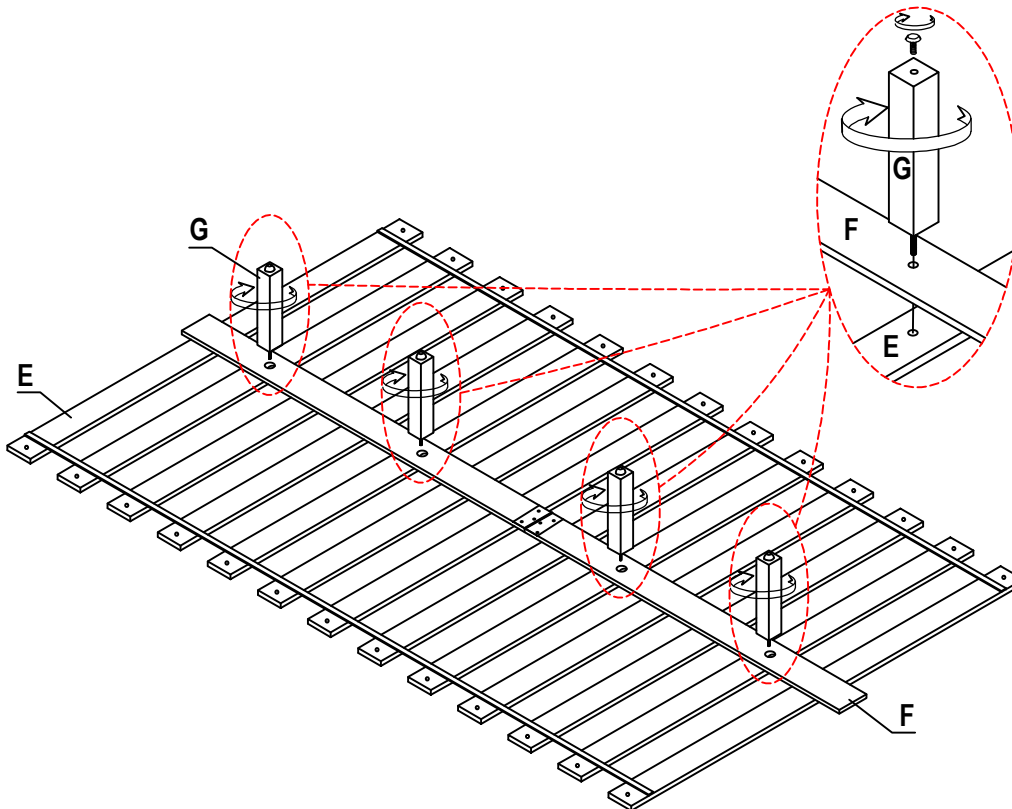

STEP 6

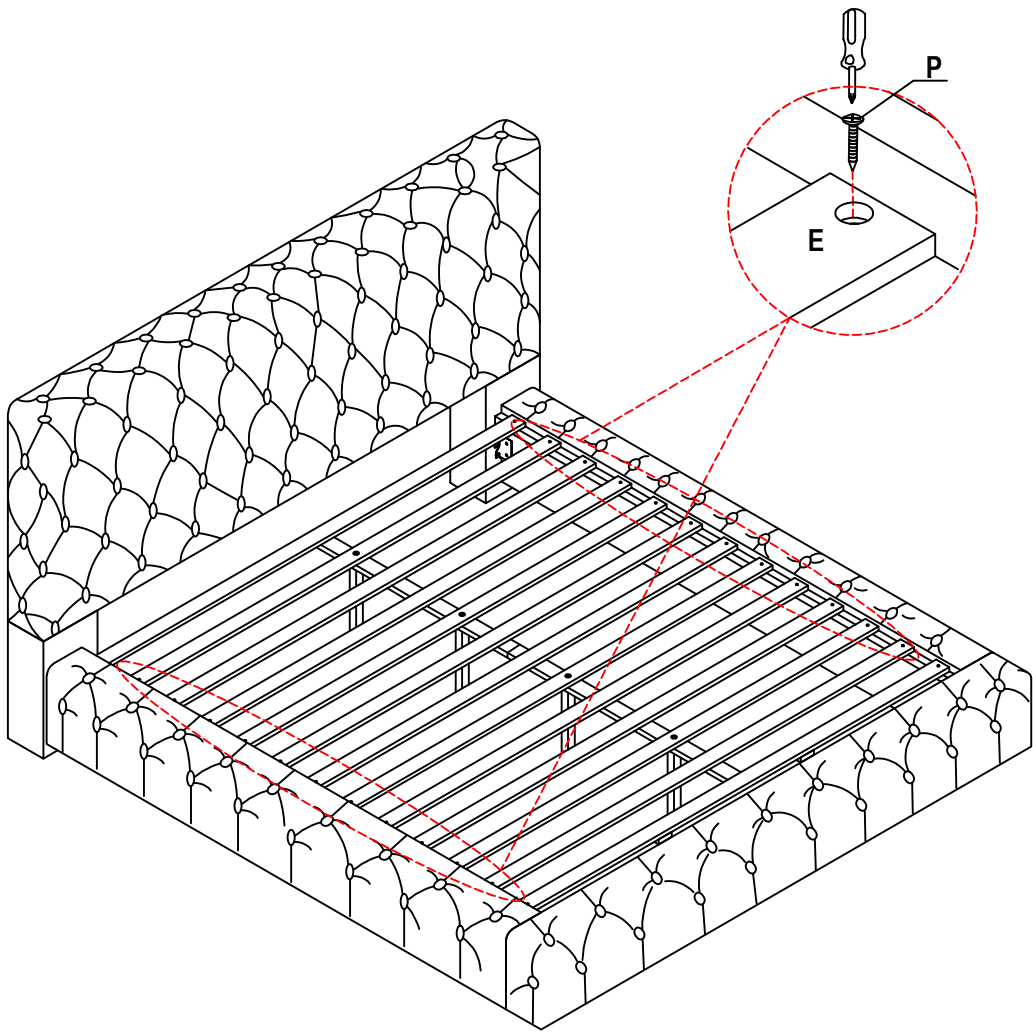

COMPLETED

