







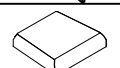

Assembly Instruction for

UPHOLSTERY SIDE CHAIR D.5270.SC / D.5273.SC

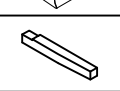
Caution: Please read instructions thoroughly before unpacking assembly parts. Sharp, exposed staple tips can cause injury, therefore, for your protection, please remove any exposed staples used in packing.

1. We recommend that you should assemble this product with the assistance of another person; this will make assembly easier, and will help to eliminate damage the product or injury to persons during assembly.
2. Be sure to check all packing materials carefully for small parts that may have come loose inside the carton during shipment.
3. Please do not over tighten screws or bolts .
4. Please put all parts on a non - abrasive floor before assembly, and follow the assembly steps to assemble your newly purchased product correctly and efficiently.

PARTS LIST				HARDWARE LIST				
No	PARTS DESC.		CODE.	Q'TY.	No	HARDWARE DESC.	CODE.	Q'TY.
A		BACK FRAME	PD.5270.SCBFR PD.5273.SCBFR	1PC	1	 BOLT 1/4" x 50mm	PD.5270. DTHW	7PCS
B		SEAT	PD.5270.SCSEA PD.5273.SCSEA	1PC	2	 BOLT 1/4" x 85mm		4PCS
C		DARK LEFT & RIGHT FRONT LEGS	PD.5270.SCLEG	2PCS	3	 SPRING WASHER Ø5/16"		12PCS
					4	 FLAT WASHER Ø5/16"		12PCS
					5	 ALLEN KEY		1PC

NOTE :Do not fully tighten any bolts until last step.

STEP 1

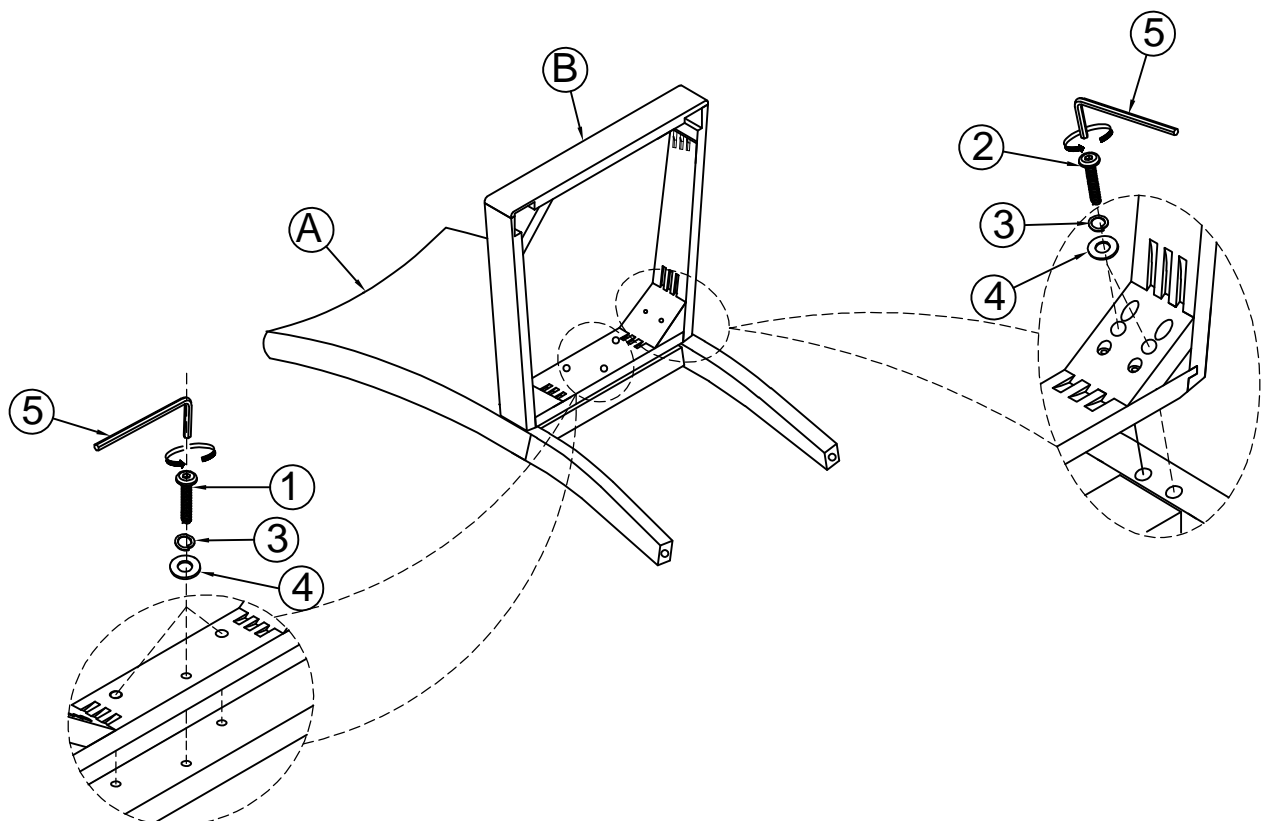

Assembly Instruction for

UPHOLSTERY SIDE CHAIR
D.5270.SC / D.5273.SC

STEP 2

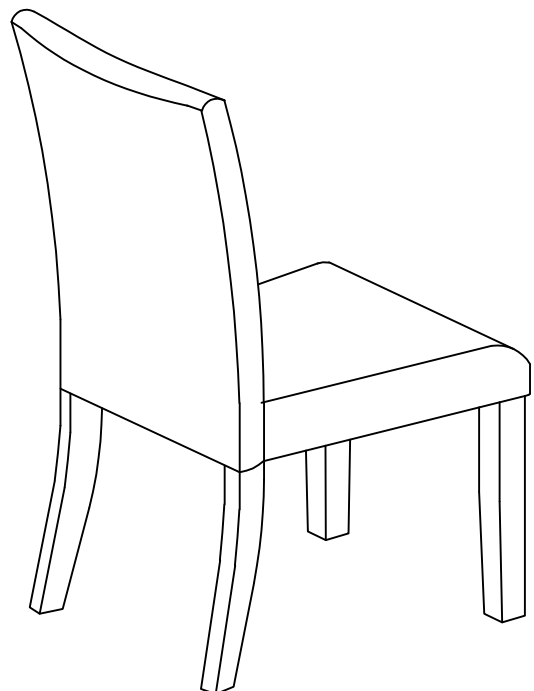
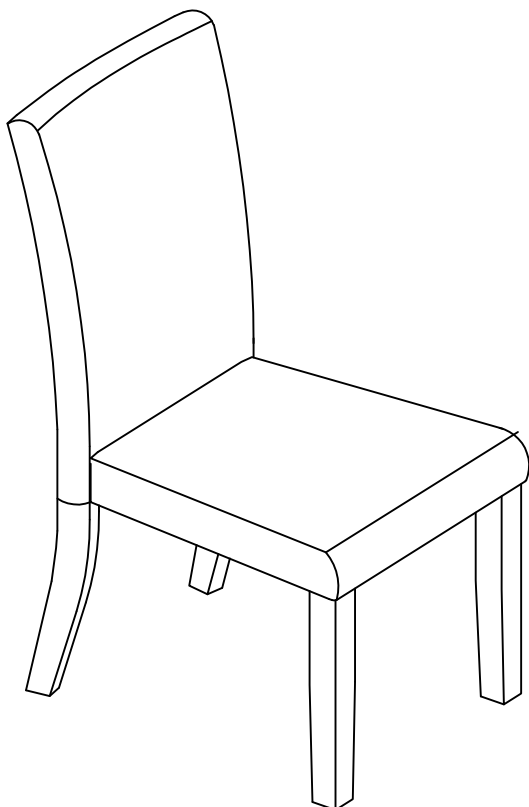
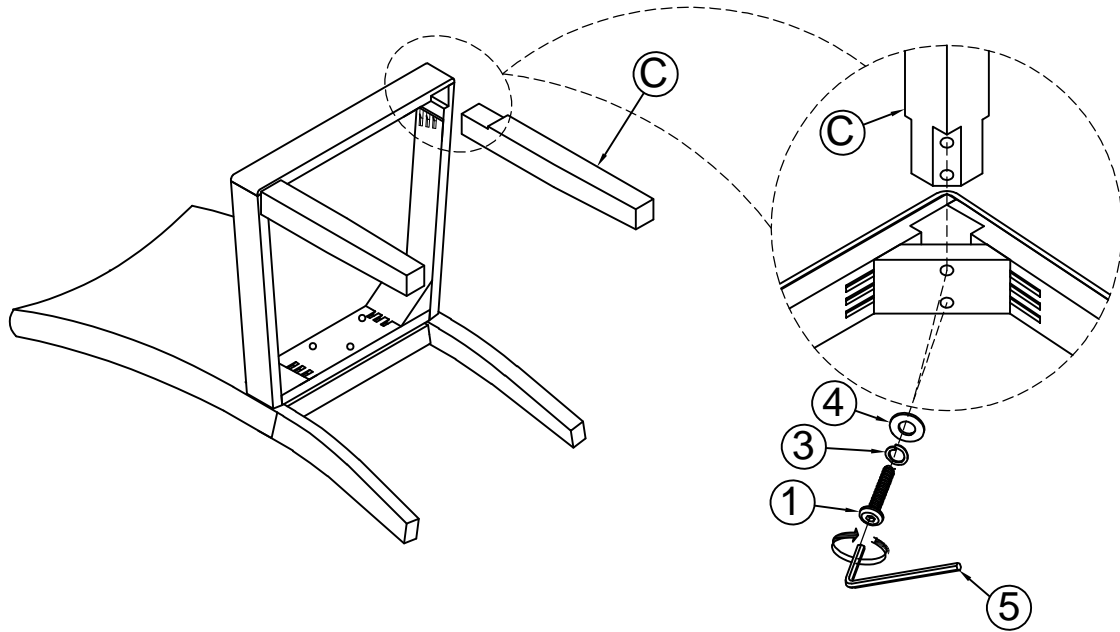

Completed Step