







Assembly Instruction for COUNTER SIDE CHAIR CFC700CVSC/CFC300CVSC

Caution: Please read instructions thoroughly before unpacking assembly parts. Sharp, exposed staple tips can cause injury, therefore, for your protection, please remove any exposed staples used in packing.

1. We recommend that you should assemble this product with the assistance of another person; this will make assembly easier, and will help to eliminate damage the product or injury to persons during assembly.
2. Be sure to check all packing materials carefully for small parts that may have come loose inside the carton during shipment.
3. Please do not over tighten screws or bolts.
4. Please put all parts on a non-abrasive floor before assembly, and follow the assembly steps to assemble your newly purchased product correctly and efficiently.

PART LIST FOR COUNTER SIDE CHAIR			
NO.	PART DESC	CODE	Q'TY
A	COUNTER SIDE CHAIR - UPHOLSTERED BACK FRAME	PCFC700CVSCBFR	1
B	COUNTER SIDE CHAIR - FULL SEAT CUSHION	PCFC700CVSCSEA	1
C	COUNTER SIDE CHAIR - LEFT / RIGHT FRONT LEGS SET	PCFC700CVSCLEG	2
D	COUNTER SIDE CHAIR - FRONT STRECHER	PCFC700CVSCSTR1	1
E	COUNTER SIDE CHAIR - LEFT / RIGHT SIDE STRECHER	PCFC700CVSCSTR2	2

HARDWARE LIST PACKED INSIDE BOX			
NO.	HARDWARE DESC	CODE	Q'TY
1	 BOLT Ø5/16"x80mm	PCFC700CVSCHW	4
2	 BOLT Ø5/16"x50mm		3
3	 BOLT Ø5/16"x55mm		4
4	 LOCK WASHER Ø5/16"		11
5	 FLAT WASHER Ø5/16"		11
6	 ALLEN KEY M5		1
7	 SCREW M8x45mm		6

STEP 1

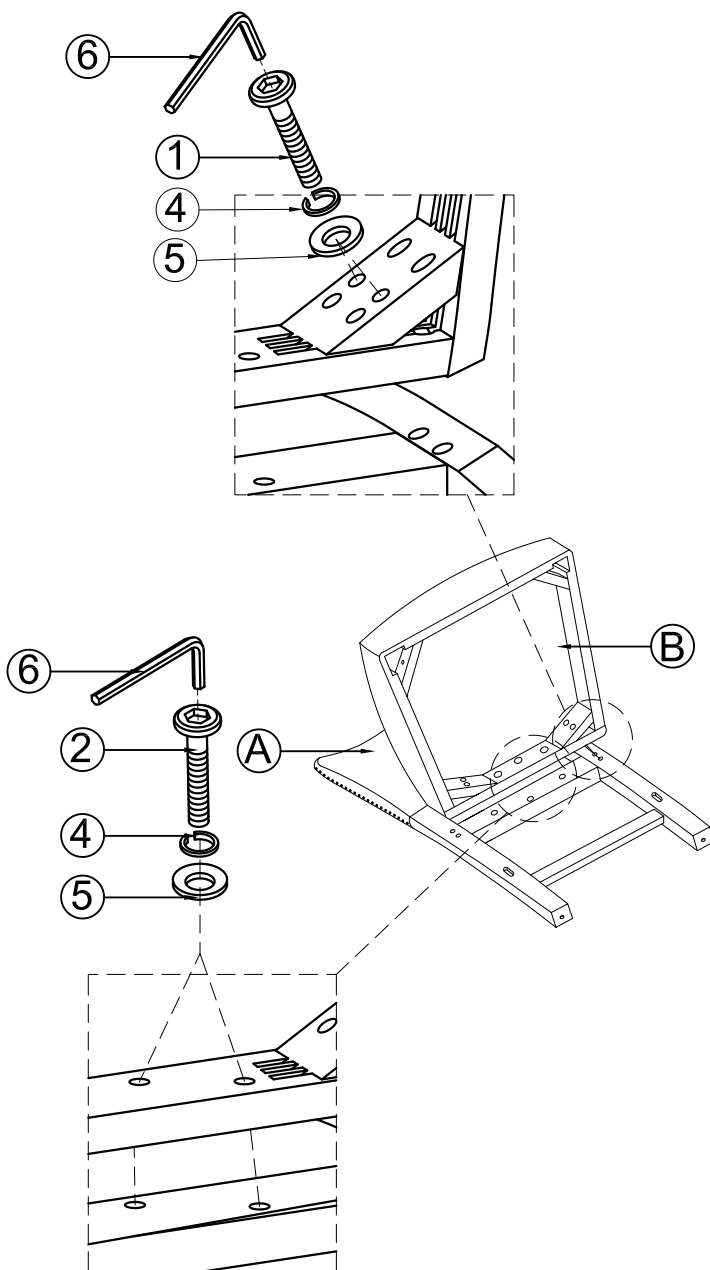

STEP 2

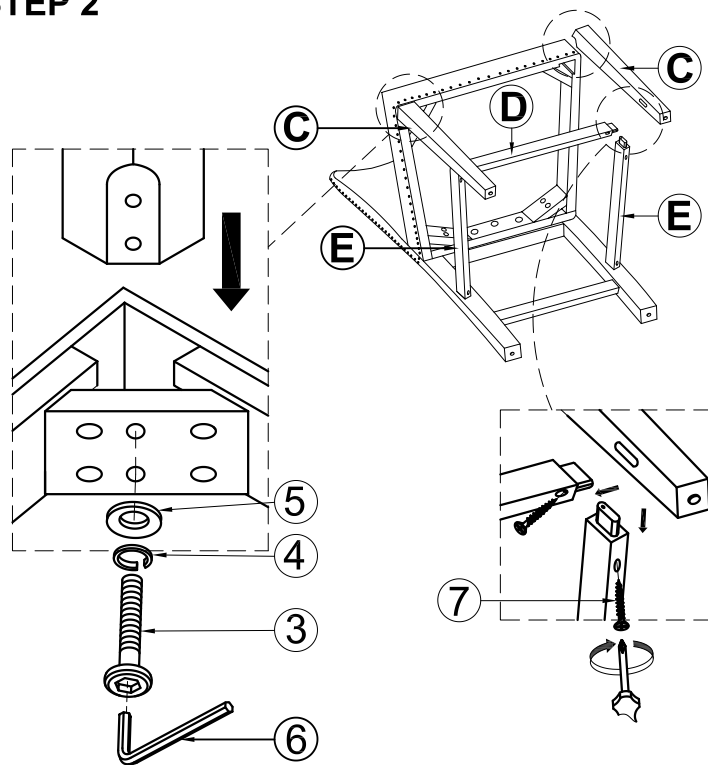

COMPLETED

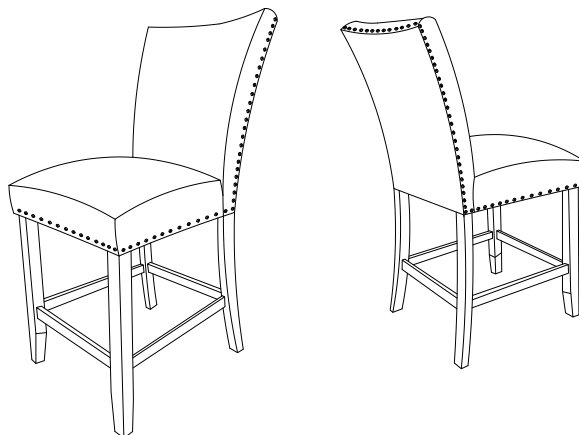

MADE IN VIETNAM