

# ALEXANDRA CAL KING/KING STORAGE BED ASSEMBLY INSTRUCTIONS

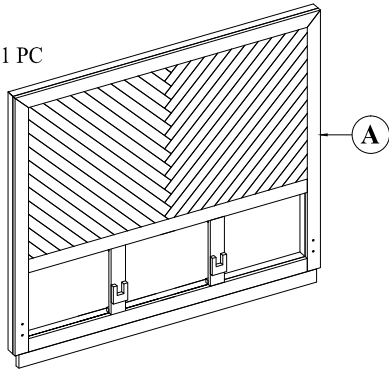

## BOX #1

A. HEADBOARD : 1 PC



## BOX #2

B. STORAGE FOOTBOARD : 1 PC  
G. SLAT ROLL : 1 SET  
H. METAL STRETCHER : 1 PC

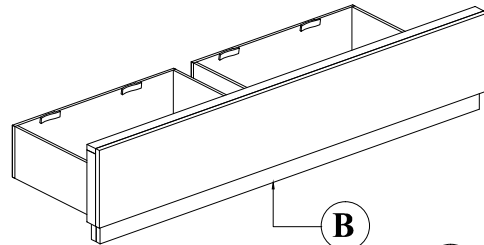

## BOX #3

C. LEFT SIDE RAIL : 1 PC  
D. RIGHT SIDE RAIL : 1 PC  
E. CENTER SLAT SUPPORT : 2 PCS  
F. SLAT SUPPORT LEG : 4 PCS

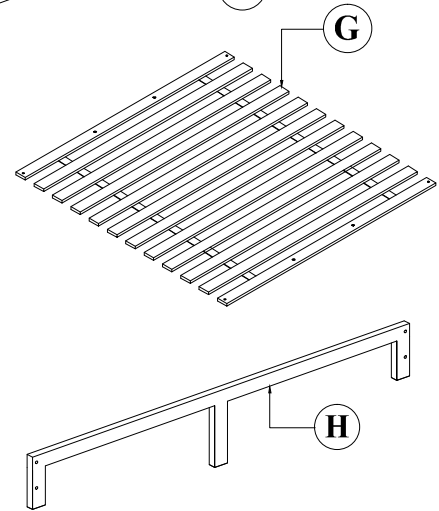
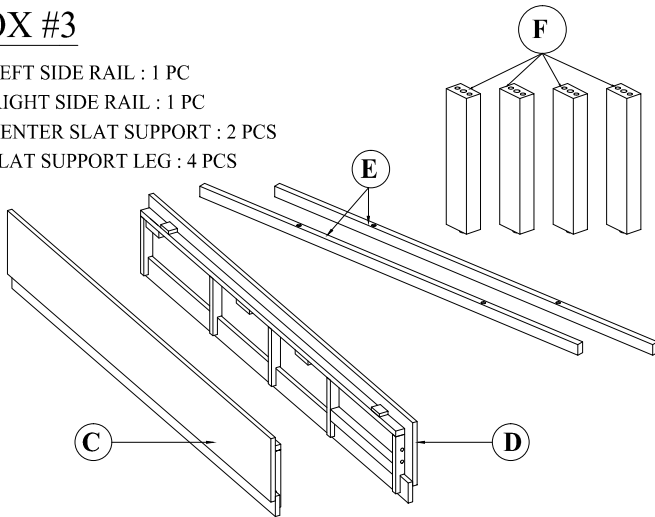

## FULLY ASSEMBLED

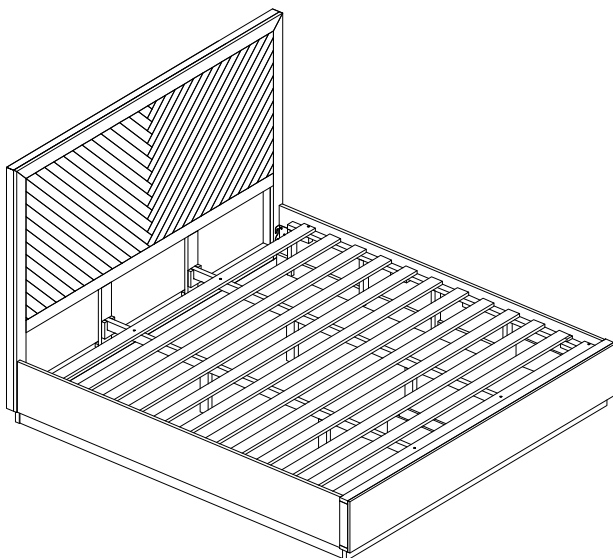

## HARDWARE PACKED IN BOX #2

1	ALLEN BOLT (M8X50)		8 PCS
2	ALLEN BOLT (M6X60)		4 PCS
3	SPRING WASHER (M8)		8 PCS
4	FLAT WASHER (M8)		8 PCS
5	WOOD DOWEL (M8X30)		8 PCS
6	WOOD SCREW (M4X30)		8 PCS
7	ALLEN KEY		1 PC

TOOL REQUIRED PHILLIPS HEAD SCREW DRIVER  
(NOT PROVIDED)

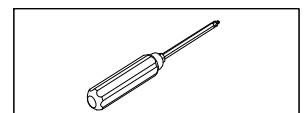

# ALEXANDRA CAL KING/KING STORAGE BED ASSEMBLY INSTRUCTIONS



## STEP 1 :

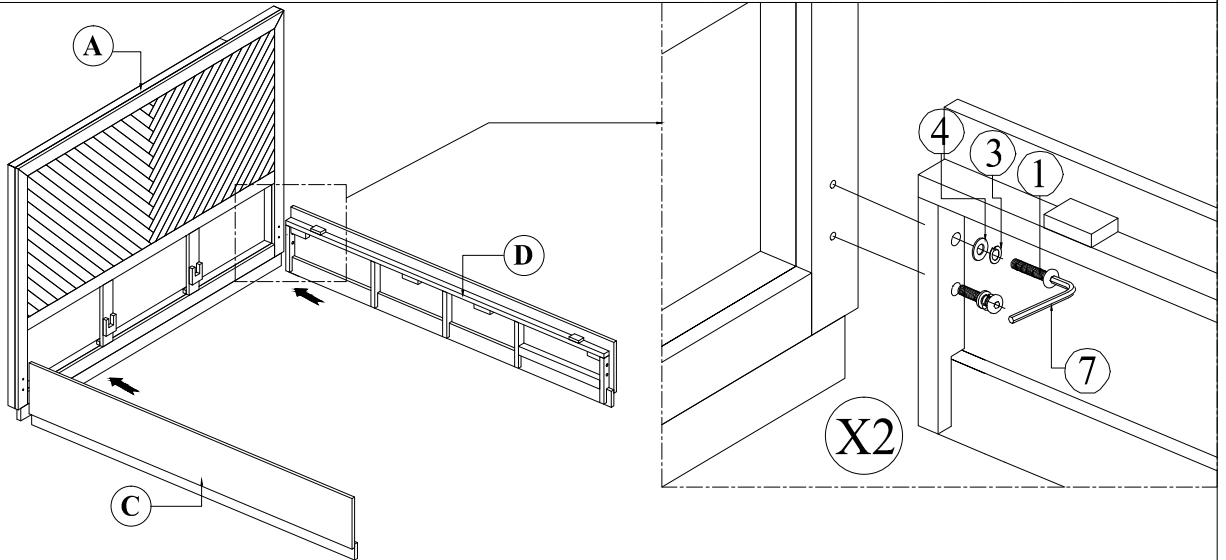

## STEP 2 :

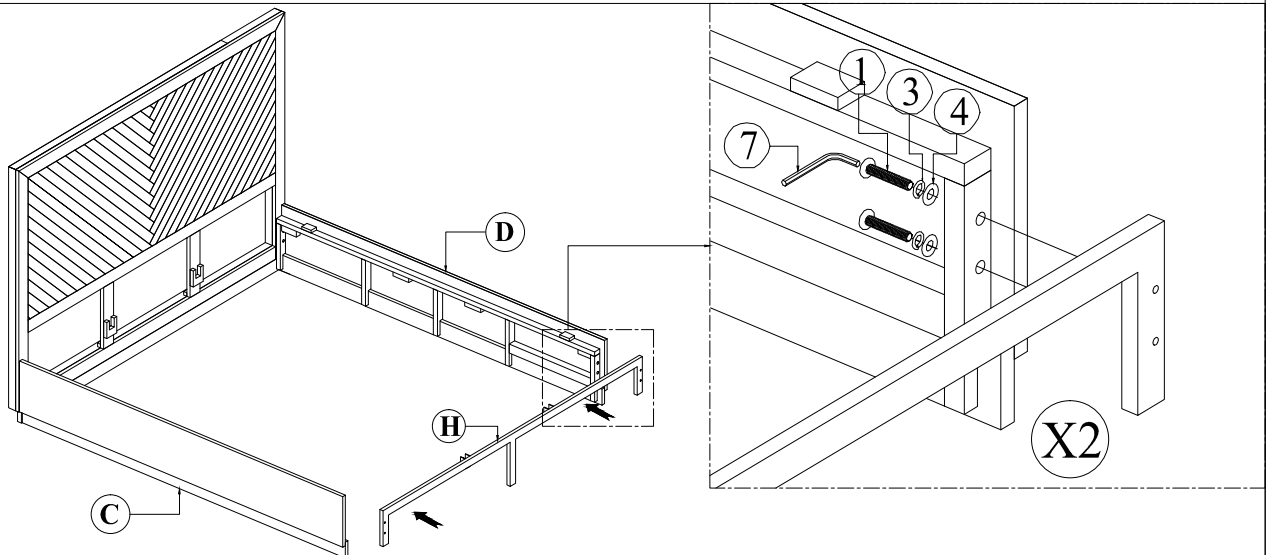

## STEP 3 :

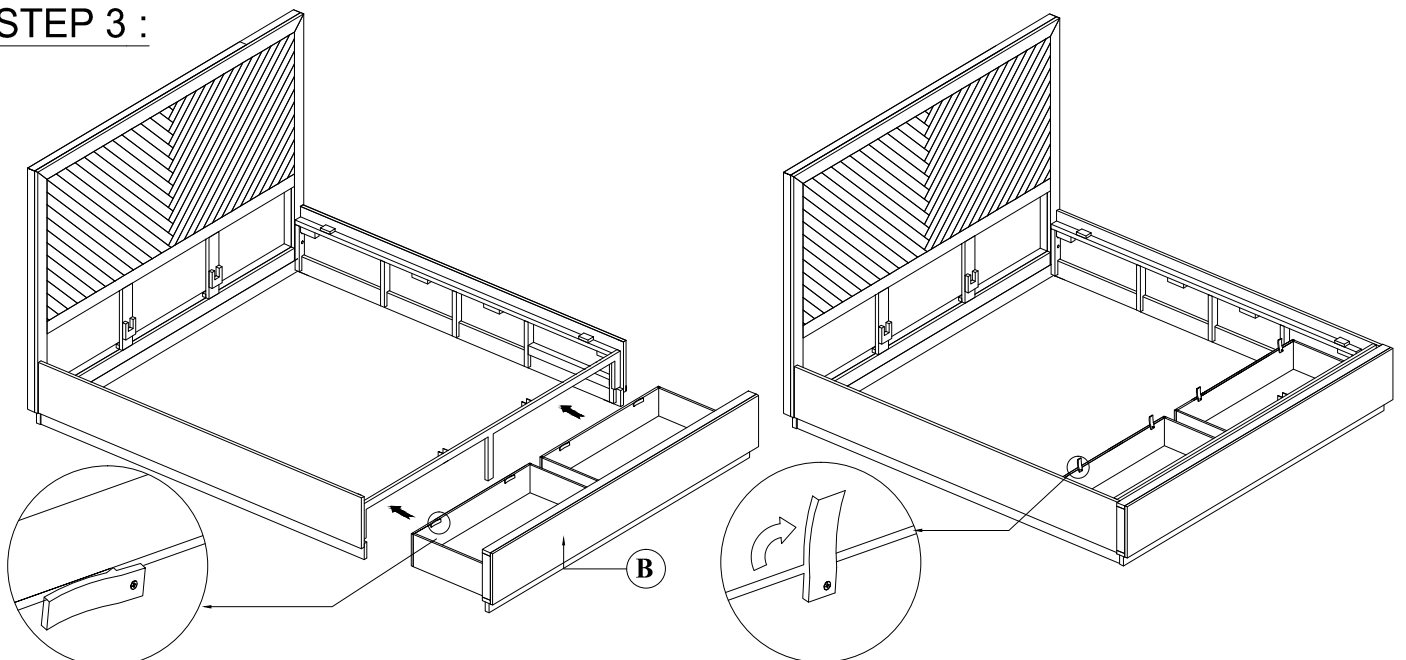

# ALEXANDRA CAL KING/KING STORAGE BED ASSEMBLY INSTRUCTIONS



## STEP 4 :

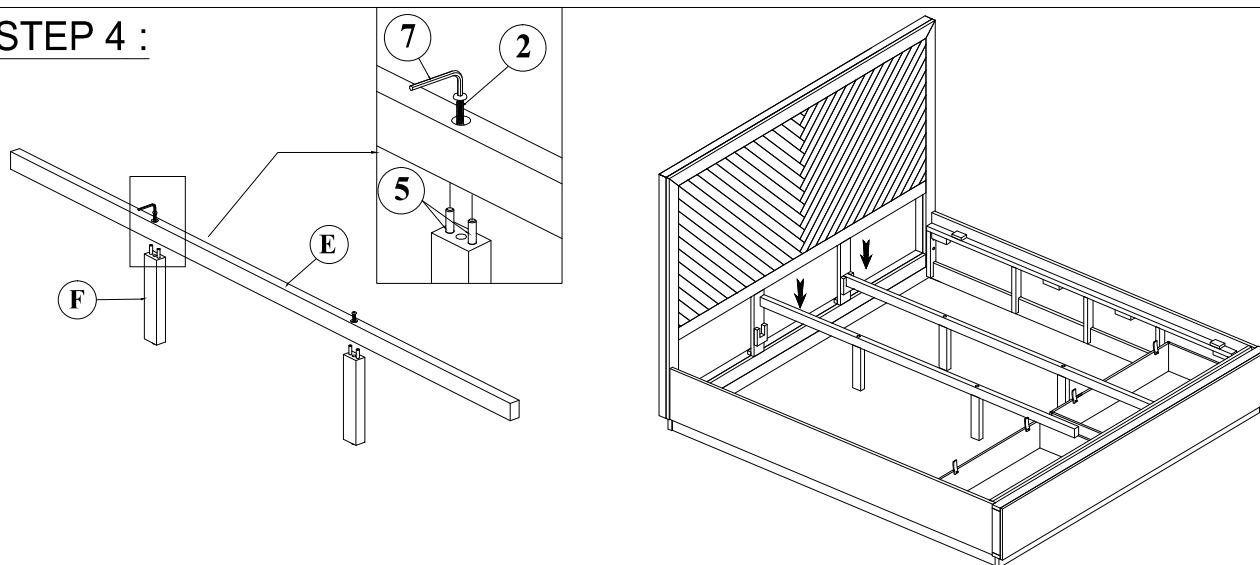

## STEP 5 :

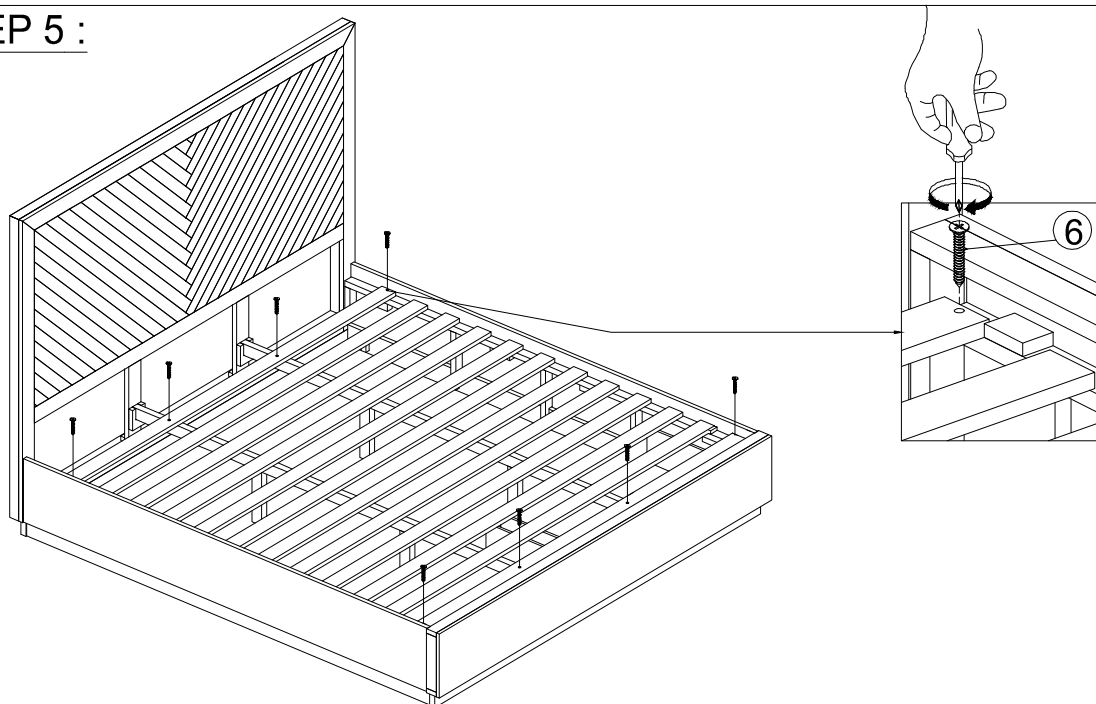

### INSTRUCTIONS FOR ADJUSTING LEVELER:

Position the bed in your space and locate the leveler under each support leg.

Turn the leveler counter-clockwise to extend the leveler and clockwise to retract it.

Adjust each leveler until each support leg is applying equal, upward pressure on the bed support slat.

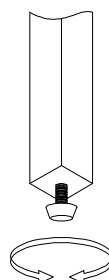

### MAINTENANCE INSTRUCTION:

- Remove box spring and mattress before moving your bed.
- Lift your bed when moving it. Dragging can damage the leg support.
- Readjust levelers after moving your bed.