

| Chair Parts Key | | | |
|-----------------|-----------------|------------------------|-------|
| No | Code | Description | Q'ty |
| 1 | 2025-340WHKDP40 | Chair Back | 1 pc. |
| 2 | 2025-340WHKDP41 | Complete Seat | 1 pc. |
| 3 | 2025-340WHKDP42 | Right Facing Front Leg | 1 pc. |
| 4 | 2025-340WHKDP43 | Left Facing Front Leg | 1 pc. |
| 5 | 2025-340WHKDP44 | Right Facing Stretcher | 1 pc. |
| 6 | 2025-340WHKDP45 | Left Facing Stretcher | 1 pc. |
| 7 | 2025-340P01F | Floor glide | 4pcs. |

| Hardware kit (2025-340WHKDP46) | | | |
|--------------------------------|--|-------------------------|---------|
| No | | Description | Q'ty |
| A | | Hexa Nut 5/16" | 4 pcs. |
| B | | Lock Washer 5/16" | 11 pcs. |
| C | | Flat Washer 5/16" | 11 pcs. |
| D | | Long Bolt 1/4"x 3" | 4 pcs. |
| E | | Short Bolt 1/4"x 1 1/2" | 3 pcs. |
| F | | Allen Key | 1 pc. |
| G | | Key Wrench | 1 pc. |
| H | | Wood Screw 1/6"x 38 | 4 pcs. |

STEP 1

- Carefully lay chair back flat on a smooth flat surface to
- Attach Complete Seat to Chair back by inserting a Flat washer (C) Lock Washer (B) with Short Bolt (E) into each of the hole on the back rail of the seat, and Long Bolt (D) into each of holes in the Complete Seat corner. (See Detail A & B)
- Tighten screws with provided Allen Key (F) by turning clockwise until secure

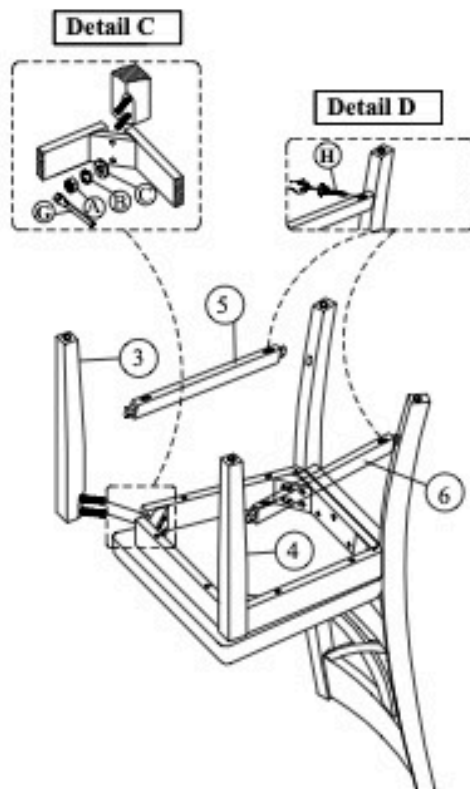
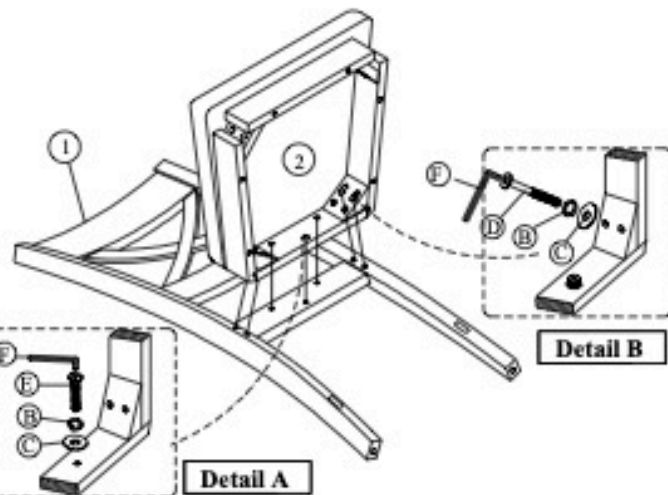

STEP 2

- Carefully turn Chair upside down and attach right and left Leg to the front corners of the Complete Seat
- Place Flat Washer (C), Lock Washer (B) and Nut (A) onfor each bolt, using provider Key Wrench (G)
- Donot fully tighten the Nuts as this stage until all the parts are in position (See Detail C)
- Insert 2 Side Stretchers between the Front leg faster wood screw driver. (not provided). (See Detail C).
- Be sure to tight all screws and nuts prior to using Chair.

