



ASSEMBLY INSTRUCTIONS

ITEM NO : B8160 - 1 & - 11
DRESSER & MIRROR



BOX OF DRESSER

| ITEM | DRAWING | DESCRIPTION | QTY |
|------|---|-------------|-----|
| A |  | DRESSER | 1 |

BOX OF MIRROR

| ITEM | DRAWING | DESCRIPTION | QTY |
|------|---|----------------|-----|
| B |  | MIRROR | 1 |
| C |  | MIRROR SUPPORT | 2 |

(BOX OF MIRROR) HARDWARE LIST

| ITEM | DRAWING | DESCRIPTION | QTY |
|------|---|--------------------------------|-----|
| 1 |  | FLAT HEAD SCREW (M4 x 32mm) | 8 |
| 2 |  | Assembly Tool Not Included | 1 |

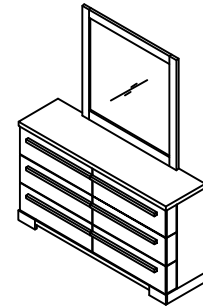

COMPLETED DRESSER & MIRROR ASSEMBLY

STEP 1

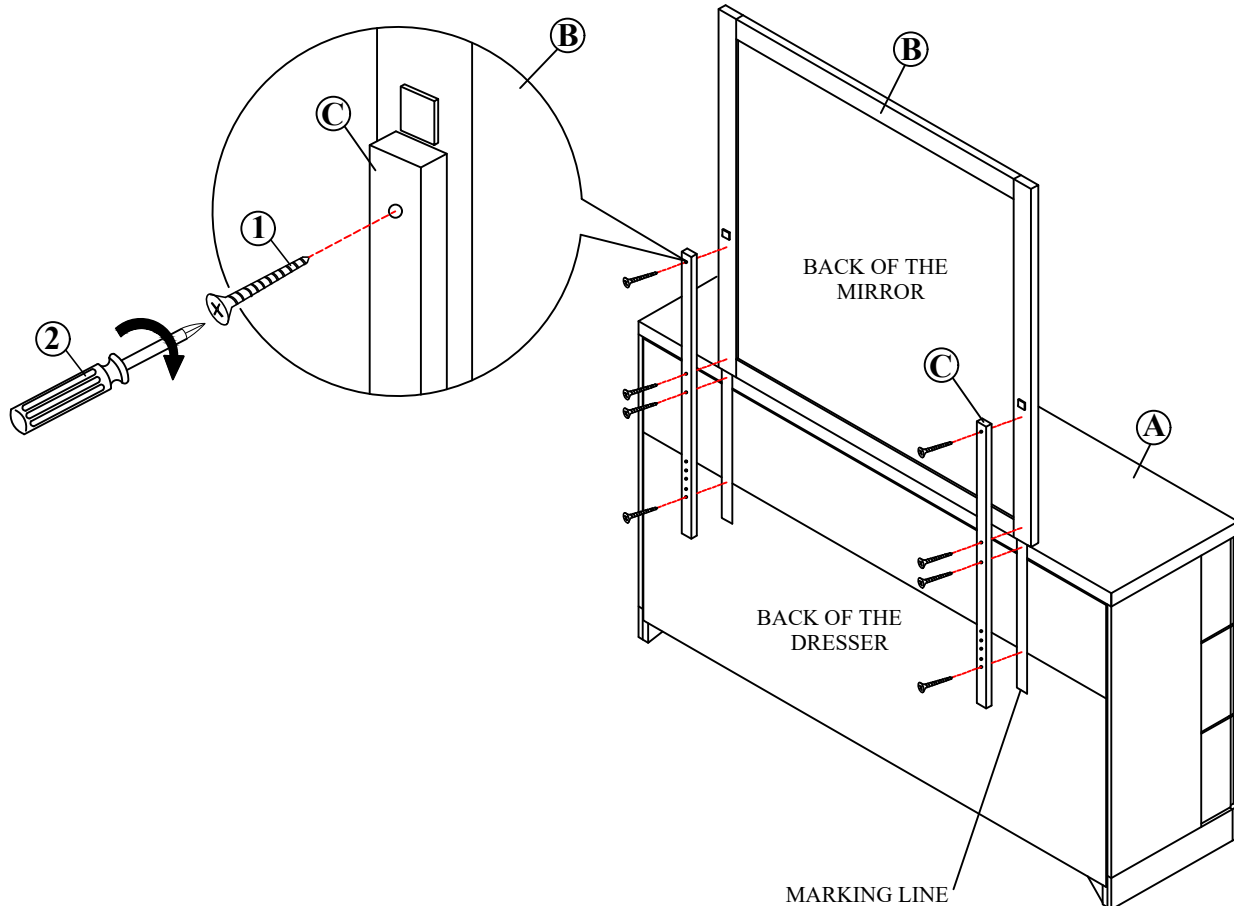

THE HARDWARE IS LOCATED IN THE PACKING ITEMS

THE ANTI TIPPING HARDWARE IS LOCATED IN THE 1ST RIGHT SIDE FRONT DRAWER OF THE DRESSER.

NOTE : MUST TIGHTEN SCREWS PERIODICALLY. WITH USE SCREW MAY BECOME LOOSE.
CHECK TIGHTNESS OF ALL SCREW EVERY 6-8 WEEKS.

CLEANING INSTRUCTION

After assembly, clean & polish the completed parts if necessary with soft cloth and industrial recognized furniture polish



MADE IN MALAYSIA