



ASSEMBLY INSTRUCTIONS

ITEM NO : B3300-11
VEDA MIRROR

BOX OF MIRROR

ITEM	DRAWING	DESCRIPTION	QTY
A		MIRROR	1
B		DRESSER TOP SUPPORT RAIL	2

BOX OF DRESSER

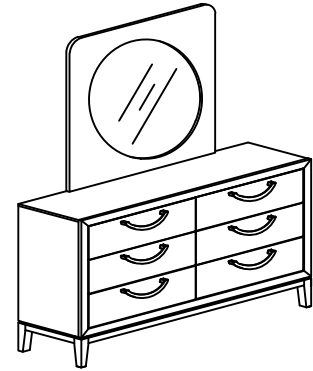

ITEM	DRAWING	DESCRIPTION	QTY
A		DRESSER	1



COMPLETED MIRROR ASSEMBLY

BOX OF MIRROR

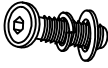
HARDWARE LIST

ITEM	DRAWING	DESCRIPTION	QTY
1		JCBC BOLT WITH SPRING WASHER AND FLAT WASHER (M6 x 35mm)	8
2		ALLEN KEY (M4)	1

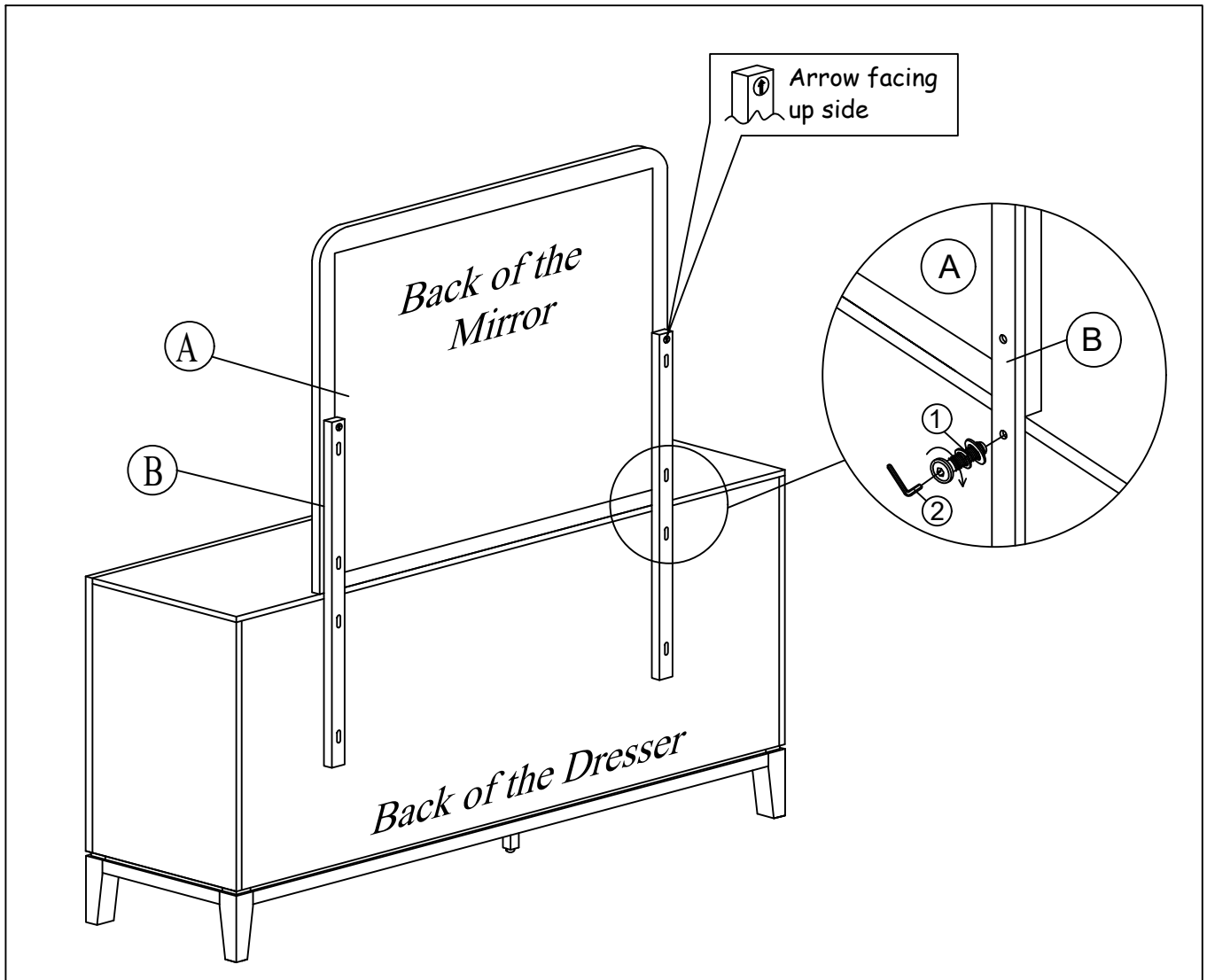

THE HARDWARE IS LOCATED IN THE PACKING ITEMS

NOTE : MUST TIGHTEN SCREWS PERIODICALLY. WITH USE SCREWS MAY BECOME LOOSE.
CHECK TIGHTNESS OF ALL SCREWS EVERY 6-8 WEEKS.



CLEANING INSTRUCTION

After assembled, clean & polish the completed parts if necessary with soft cloth and industrial recognized furniture polish

MADE IN MALAYSIA