

ASSEMBLY INSTRUCTION

ITEM : 5264WH-Q-HBFB / 5264WH-KQ-RAIL

PART LIST

BOX 1 : BOX OF HEADBOARD/FOOTBOARD

1. HEADBOARD
CUSHION

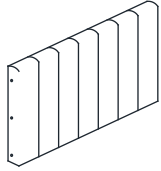

x 1PC

2. HEADBOARD
LEG (LEFT)

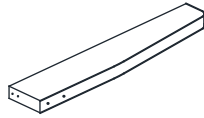

x 1PC

3. HEADBOARD
LEG (RIGHT)

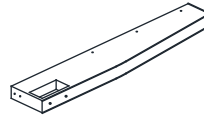

x 1PC

4. FOOTBOARD
CUSHION

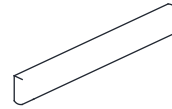

x 1PC

5. FOOTBOARD
LEG



x 4PCS

6. SLAT

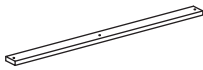

x 4PCS

7. SUPPORT LEG
with adjustable feet



x 4PCS

BOX 2 : BOX OF SIDE RAIL

8. SIDE RAIL
(LEFT)

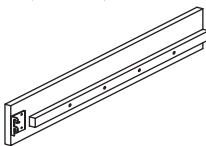

x 1PC

9. SIDE RAIL
(RIGHT)

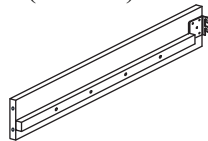

x 1PC

HARDWARE LIST

BOX 1 : BOX OF HEADBOARD/FOOTBOARD

A. JCBB SCREW
M8 x 20mm



x 4PCS

B. JCBB SCREW
M8 x 70mm
(with washer)

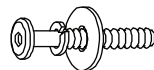

x 4PCS

C. JCBC SCREW
M6 x 35mm

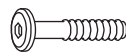

x 4PCS

D. JCBC SCREW
M6 x 50mm
(with washer)

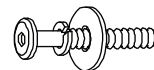

x 6PCS

E. JCBC SCREW
M6 x 70mm



x 4PCS

F. WOOD DOWEL
M8 x 30mm



x 4PCS

G. SCREW
M4 x 32mm

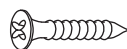

x 8PCS

H. L-KEY
M4 x 100mm



x 1PC

I. L-KEY
M5 x 65mm



x 1PC



THE HARDWARE IS LOCATED IN THE PACKING ITEM

ASSEMBLY INSTRUCTION

STEP 1

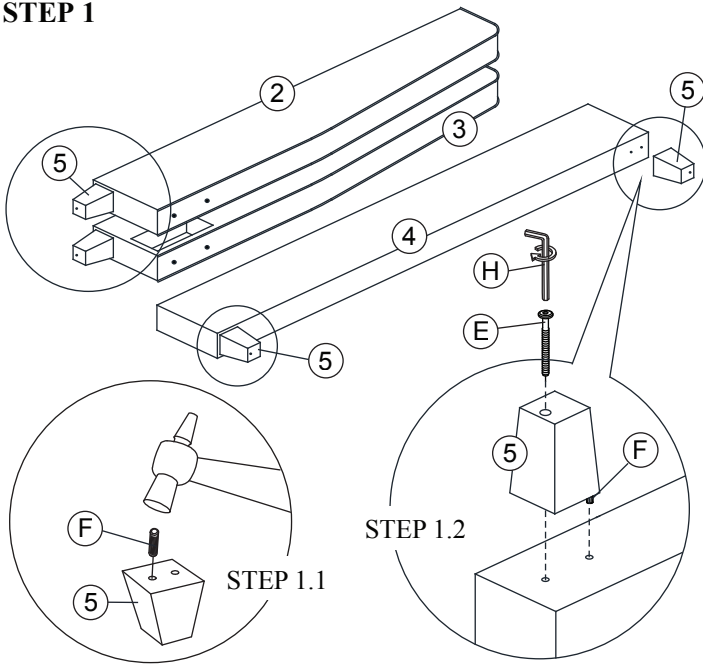

STEP 2

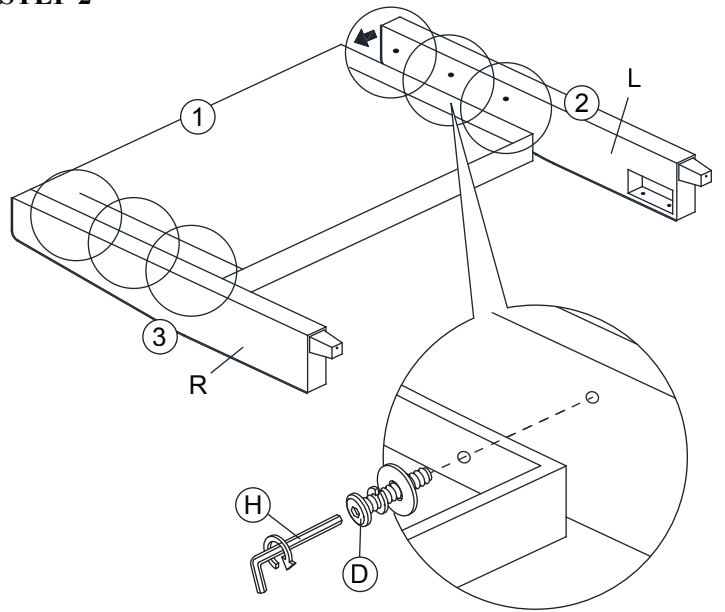

STEP 3

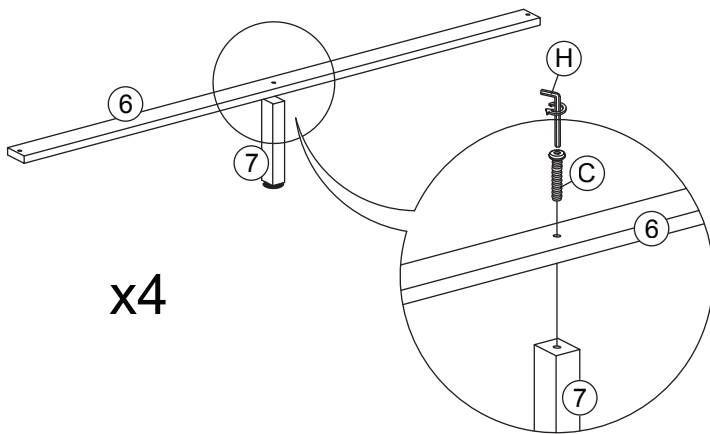

STEP 4

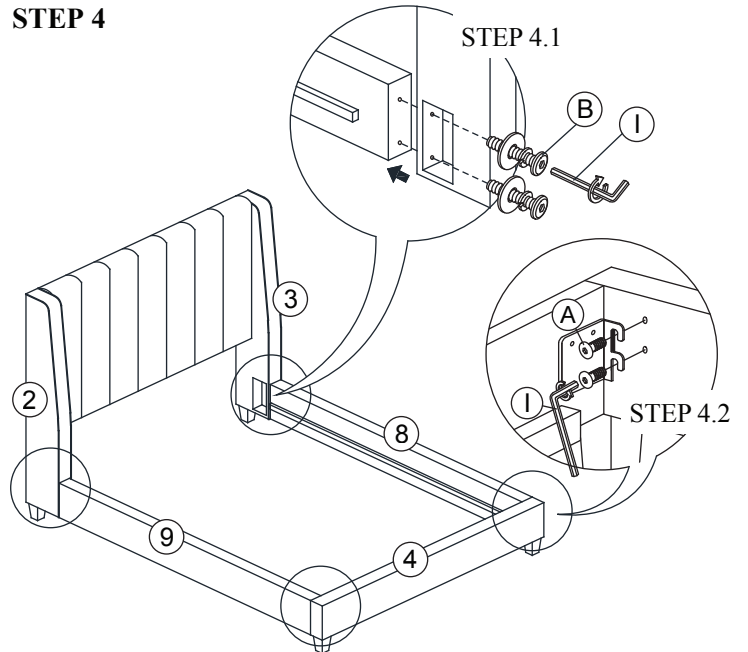

STEP 5

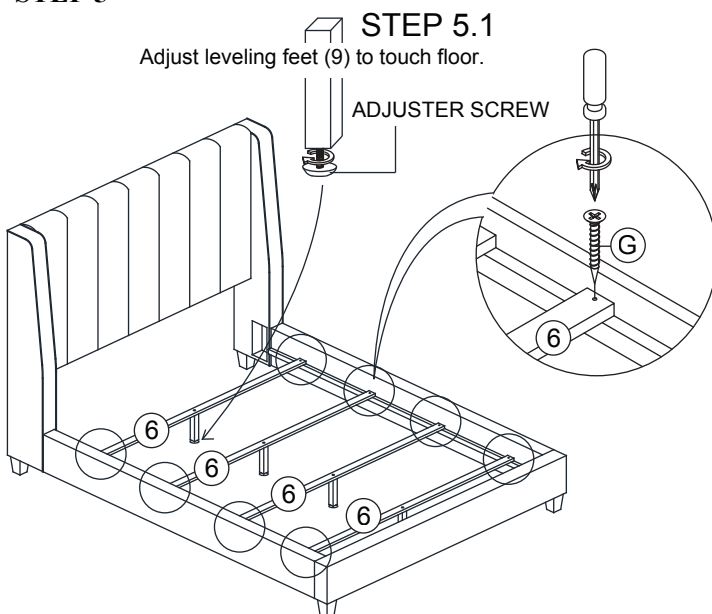

STEP 6

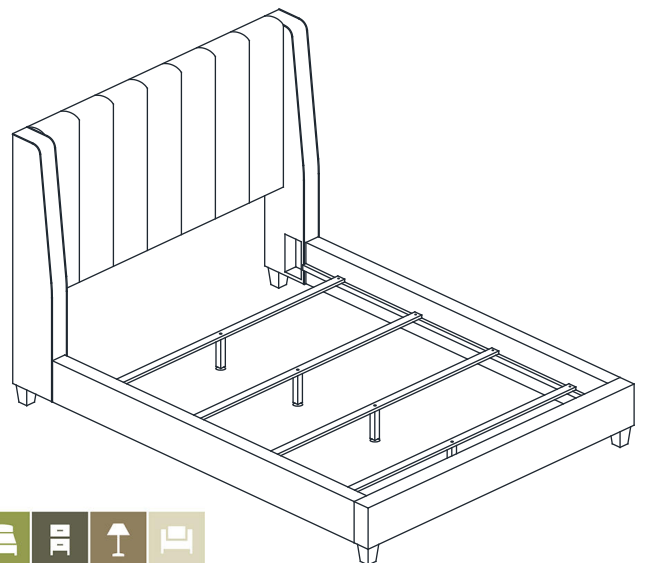

ASSEMBLY COMPLETE