

# Assembly Instructions

## BUNGIE Low Back Office Chair

PLEASE NOTE: Check that you have received all components and hardware before assembling. If you are missing any parts, contact your retailer.

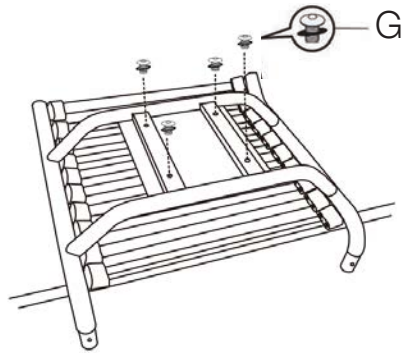

**IMPORTANT NOTE:** Screws and washers (Parts G) are preassembled into the underside of the seat (Part B). Remove screws and washers from seat and then use to attach Part C to Part B, as shown in step 1.

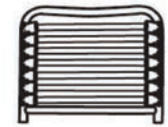
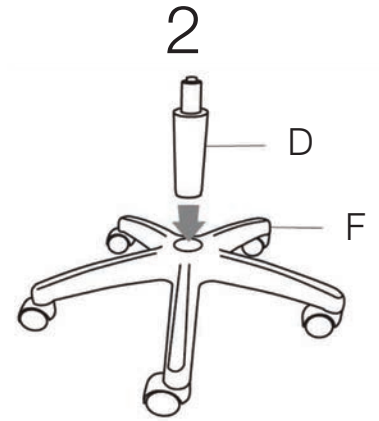
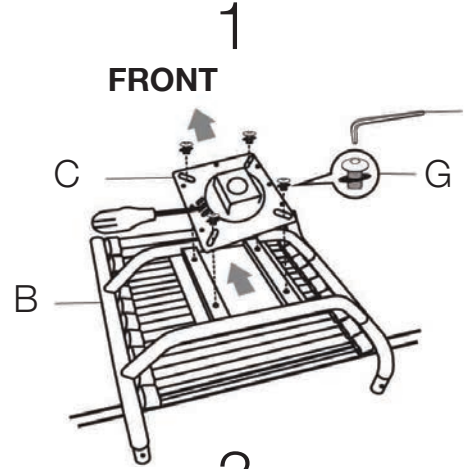

A (1 pc)



B (1 pc)

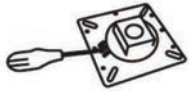

C (1 pc)



D (1 pc)



E (1 pc)



F (1 pc)

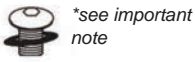

G (4 pcs)  
M8 x 14mm



H (2 pcs)  
1/4" x 5/8"



I (1 pc)  
5mm



J (1 pc)  
4mm

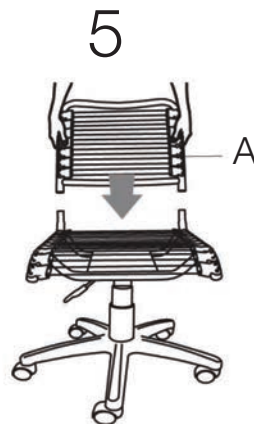
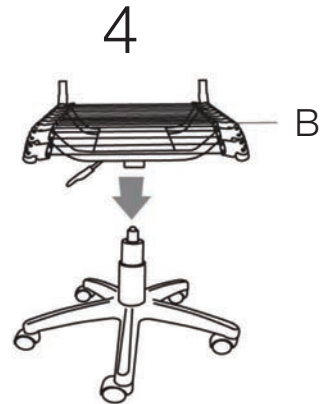
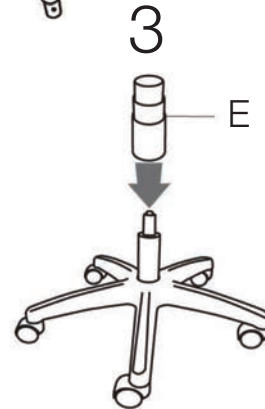

### Function Description

\* Pull up to adjust chair height



During assembly, hand tighten screws only. When the screws are in place, tighten completely.