

Thank You for purchasing this Quality product. It has been engineered for easy assembly yet constructed for durability. Please take the time to read and follow the instructions while assembling. Please be sure to read the Notes section at the bottom of the page before beginning Assembly. Thank You

ASSEMBLY INSTRUCTION

END TABLE

Model : T137-04 (DOVT 2107-2)

SIZE : 23-5/8" x 23-5/8" x 23-5/8"H

Step 1

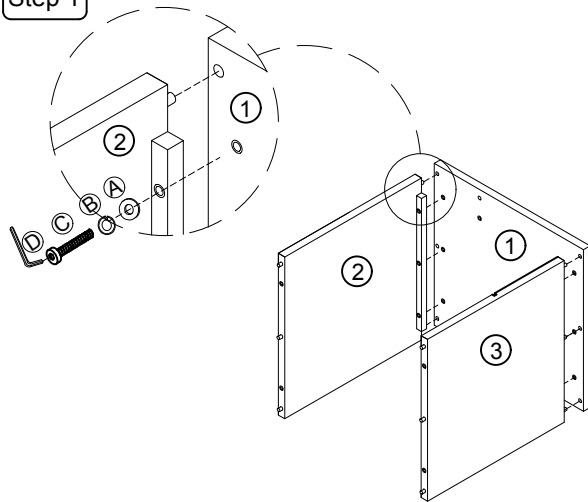

Step 3

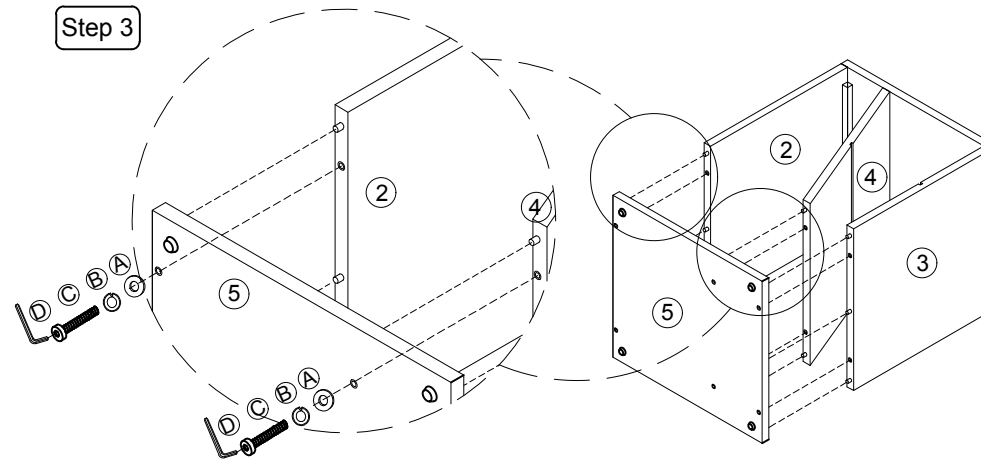

List of Part For 1 Set

| Code | Figure | Part | Qty. |
|------|--------|----------------------|------|
| ① | | Table Top | 1 |
| ② | | Side Panel - Left | 1 |
| ③ | | Side Panel - Right | 1 |
| ④ | | Divided Panel | 1 |
| ⑤ | | Bottom Panel | 1 |
| ⑥ | | Tempered Glass Shelf | 1 |

Step 2

INSERT WOOD DOWEL BEFORE ASSEMBLE

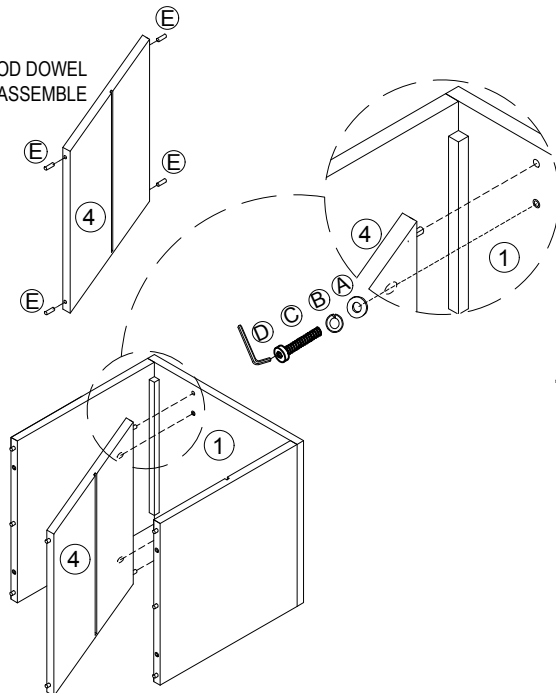

Step 4

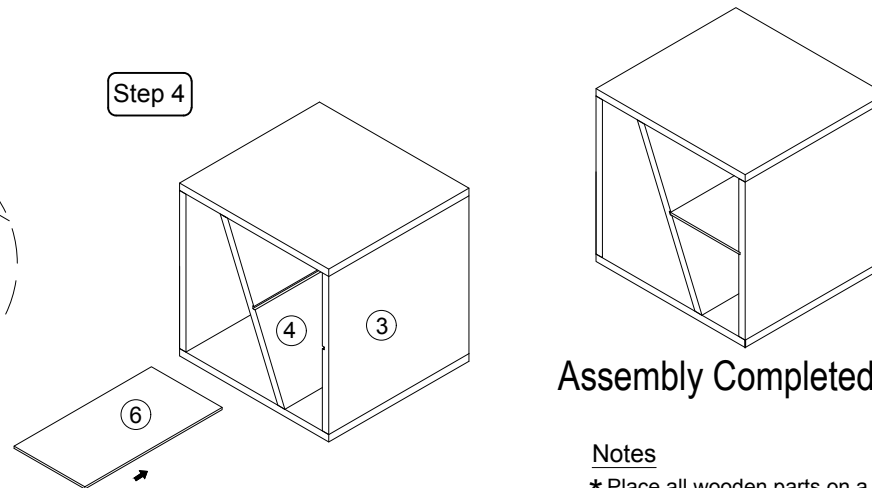

List of hardware For 1 Set

| Code | Figure | Hardware | Qty. |
|------|--------|-------------------------|------|
| (A) | | Flat Washer 1/4" x 13mm | 14 |
| (B) | | Spring Washer 1/4" | 14 |
| (C) | | JCBC M6 x 35mm | 14 |
| (D) | | Allen Key M4 | 1 |
| (E) | | Wood Dowel M10x30mm | 4 |

Assembly Completed !!

Notes

- * Place all wooden parts on a clean and smooth surface such as a rug or carpet to avoid the parts from being scratched.
- * Check to be sure that you have all parts and hardware.
- * Remove all wrapping materials including staples & packing straps before you start to assemble.
- * Do not tighten all screws / bolts until all completely assembled.

⚠ Important Notes

- * Keep all hardware parts out of reach of children.
- * Must tighten screws periodically. With use screws will become loose. Check tightness of all screws every 6-8 weeks.
- * Don't attempt to repair or modify parts that are broken or defective. Please contact the store immediately.
- * Do not tighten all screws / bolts until all completely assembled

MADE IN MALAYSIA