





LIVING SPACES

ASSEMBLY INSTRUCTIONS



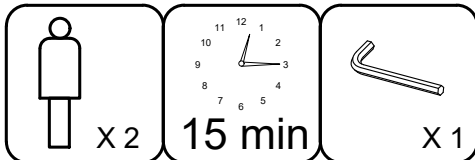
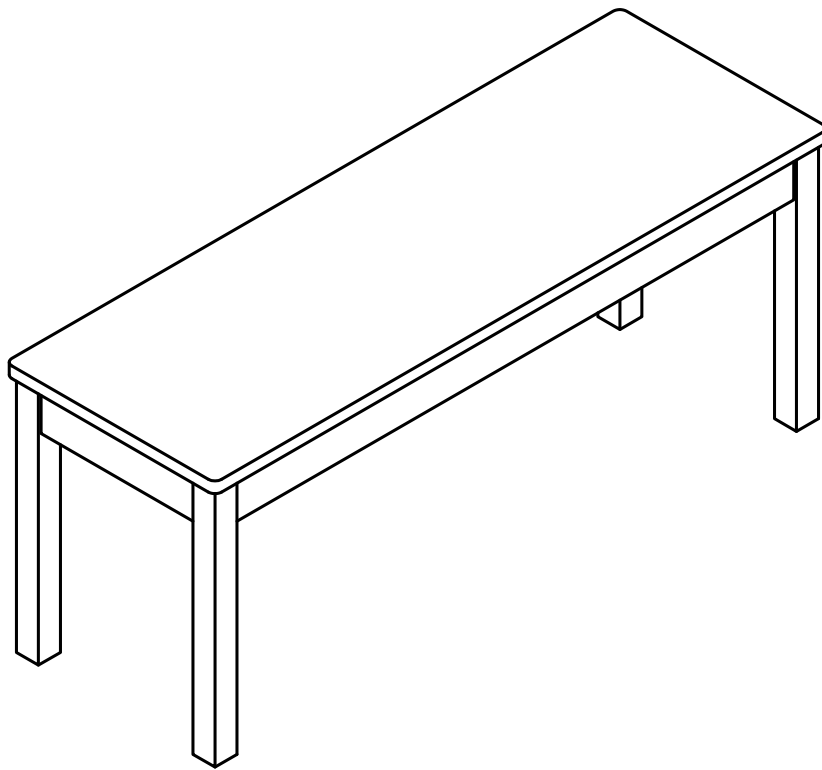

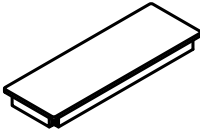
ORTA DINING BENCH

ITEM: D2111-223 SKU:323812



PART	SKU#	IMAGE	DESCRIPTION	QTY
Ⓐ	323812-A		BENCH TOP	1
Ⓑ	323812-B		LEGS	4

Hardware list of *ORTA DINING BENCH*

PART	SKU#	IMAGE	DESCRIPTION	QTY
①	323812-4(1)		Allen key 60x22x4mm	1
②	323812-2(8)		Spring washer Ø1/4"x13	8
③	323812-3(8)		Flat washer Ø1/4"x19	8
④	323812-1(8)		Bolt 1/4"x60mm	8

Note: Screwdriver will be prepared by yourself.

THE HARD WARE IS LOCATED IN THE PACKING ITEM

NOTE: MUST TIGHTEN SCREWS PERIODIACLLY. WITH USE SCREW MAY ENCOME LOOSE CHECK TIGHTNESS OF ALL SCREWS EVERY 6-8 WEEKS.

CLEANING INSTRUCTIONS:

After assembly, clean and polish the completed parts if necessary with soft cloth and industrial recognized furniture polish.

DETAIL VIEW

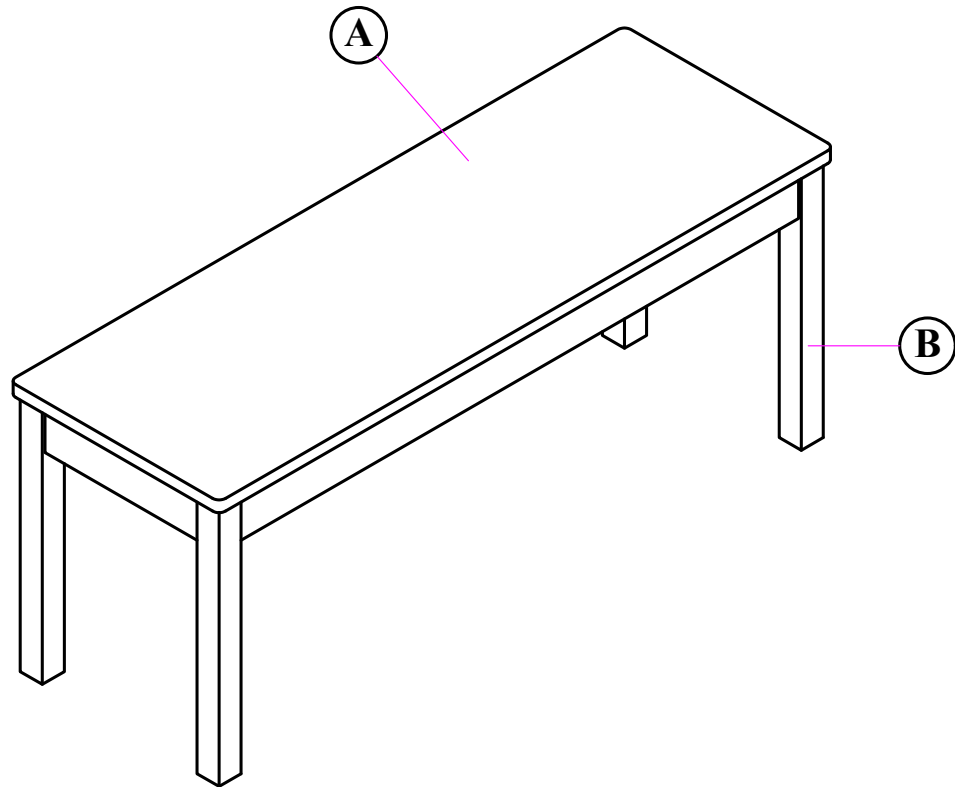

STEP 1:

* Attach the Legs (B) to Bench Top (A) by using Flat Washer (3), Spring Washer (2), Bolt (4) and tighten with Allen Key (1).

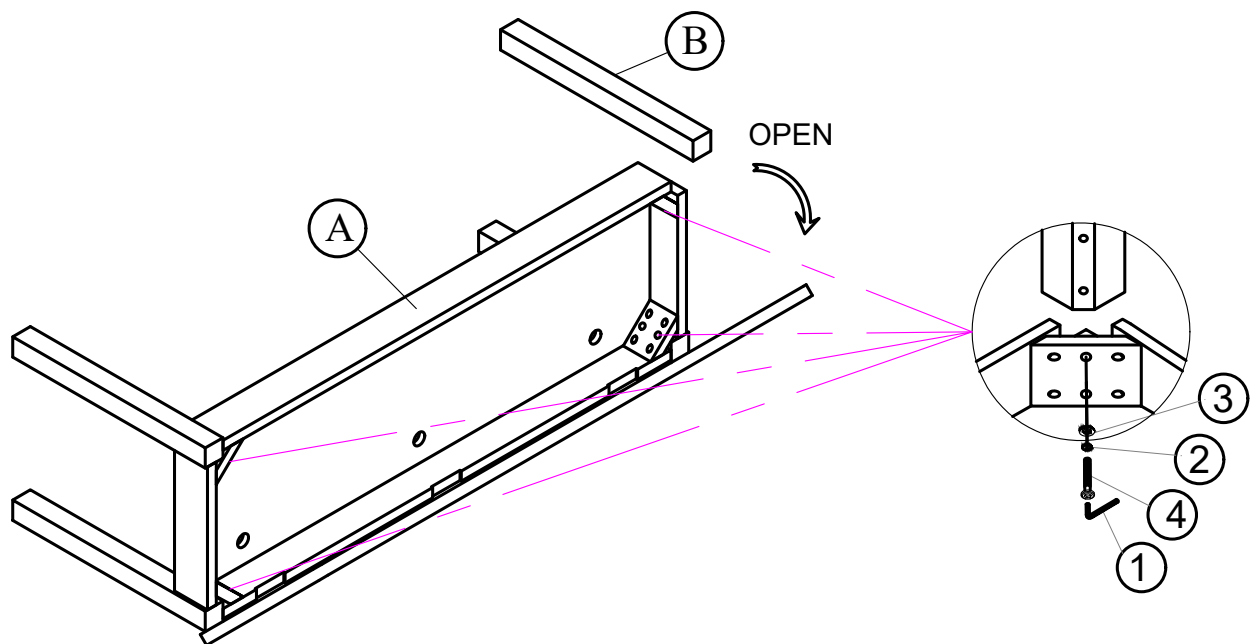

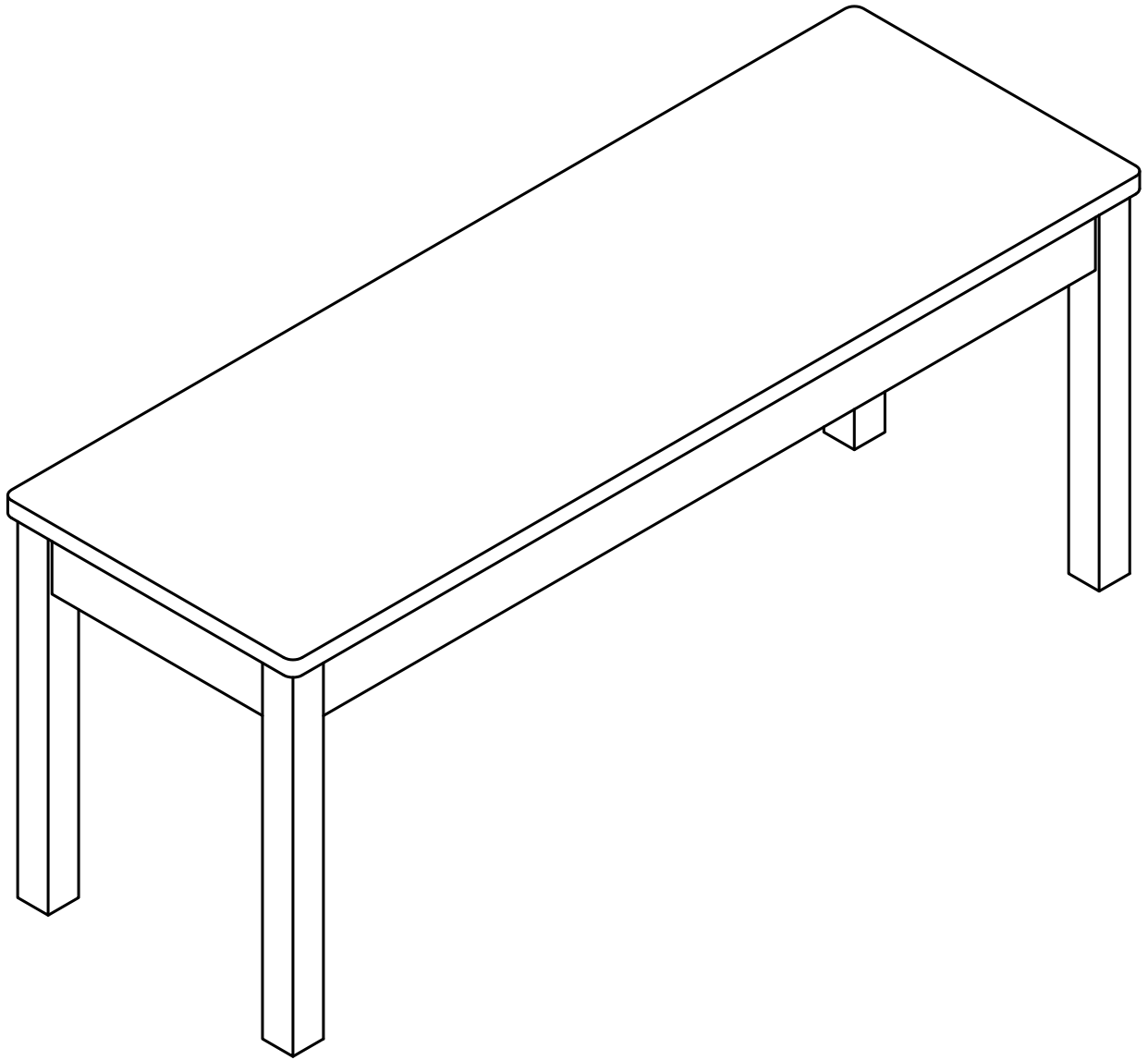

***That's it ! You've finished
assembling your item. Thank you!***