

# ASSEMBLY INSTRUCTIONS

**CROWNMARK**  
**MODEL : 5109GY-Q/5109GY-F**  
**QUEEN/FULL**  
**PLATFORM BED**

## PART LIST

No	ITEM	Qty
A	Front & Back Panel	2 pcs
B	Leg (L&R)	4 pcs
C	Side Rail Left (L)	2 pcs
D	Side Rail Right (R)	2 pcs
E	Side Rail Leg	2 pcs
F	Slats (x6)	2 sets
G	Center Rail Supprt	2 pcs
H	Slat Support	4pcs

## HARDWARE LIST

No	ITEM	Qty
1	JCBC M6 x 35mm	8 pcs
2	JCBC M6 x 50mm	8 pcs
3	Spring Washer 1/4" Rbw	12 pcs
4	Flat Washer 1/4"ID x 13mmOD Blk	12 pcs
5	Wood Dowel 8 x 30mm	8 pcs
6	Csk M4 x 32mm	24 pcs
7	ALLEN KEY m4x65mm Blk	1 pc
8	ALLEN KEY m5x65mm Blk	1 pc

### STEP 1

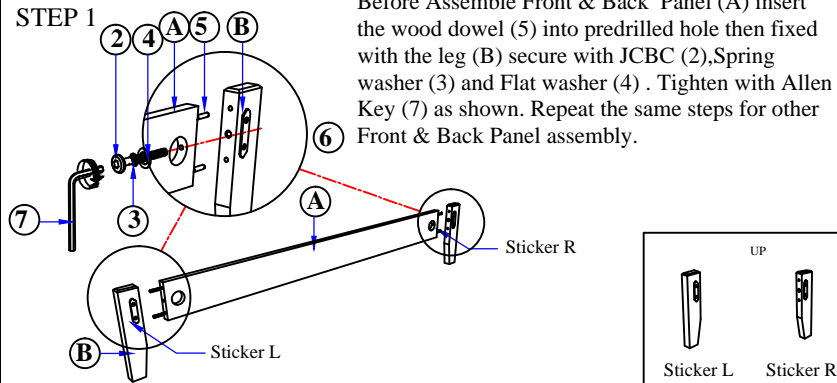

### STEP 2

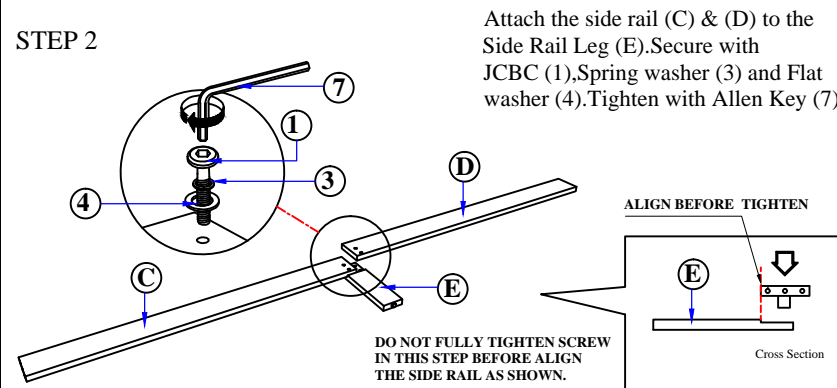

### STEP 3

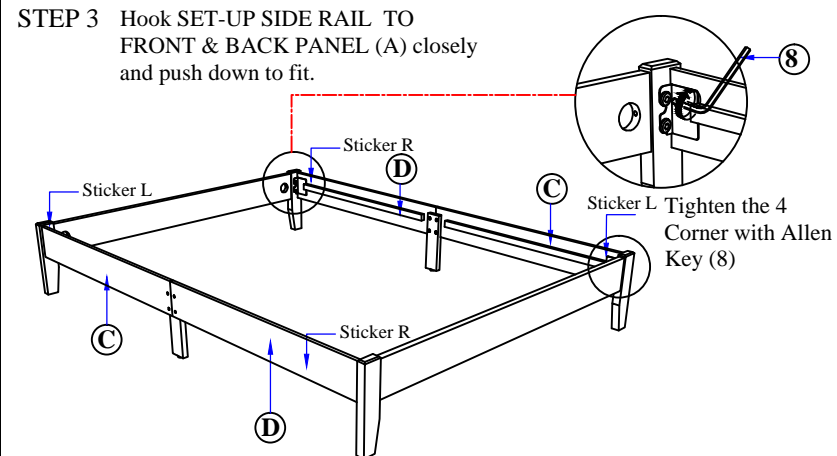

### STEP 4

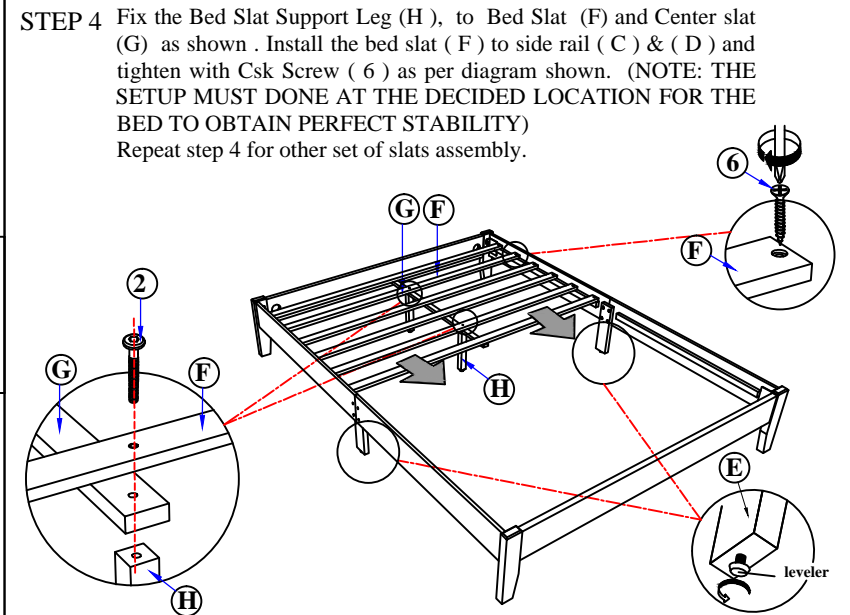

## COMPLETE

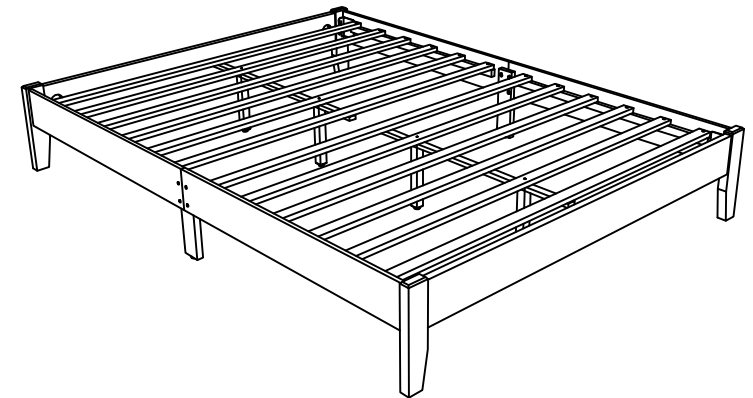

NOTE : MUST TIGHTEN SCREWS PERIODCALLY WITH USE SCREW WILL BECOME LOOSE CHECK TIGHTNESS OF ALL SCREW EVERY 6-8 WEEKS.