



**ASSEMBLY INSTRUCTIONS**  
**COASTER FINE FURNITURE**



*Fine Furniture for every stage of life*

REVISION 0 :12/09/2019  
REVISION 1 :04/16/2021

**PAGE 1 OF 4**

**881197**  
**OFFICE CHAIR**

[COASTERFURNITURE.COM](http://COASTERFURNITURE.COM)

ITEM: **881197**



## ASSEMBLY INSTRUCTIONS

### ASSEMBLY TIPS:

1. Remove hardware from box and sort by size.
2. Please check to see that all hardware and parts are present prior to start of assembly.
3. Please follow attached instructions in the same sequence as numbered to assure fast & easy assembly.



### WARNING!

1. Don't attempt to repair or modify parts that are broken or defective. Please contact the store immediately.
2. This product is for home use only and not intended for commercial establishments.



ASSEMBLY TIME

10 MINUTES

## PARTS IDENTIFICATION

A BASE



1PC

B LEG



5PCS

C CASTER



5PCS

D GAS CYLINDER



1PC

E ADJUSTING  
PLATE

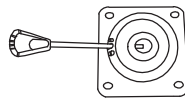

1PC

F SEAT AND BACK

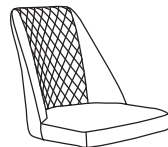

1PC

1 ALLEN  
WRENCH  
(M6)



1PC

2 BOLT  
(M6 x 20mm)



4PCS

3 BOLT  
(M6 x 10mm)



5PCS

4 WASHER  
( $\phi$  6 x  $\phi$  18mm)



4PCS

**ASSEMBLY INSTRUCTIONS**

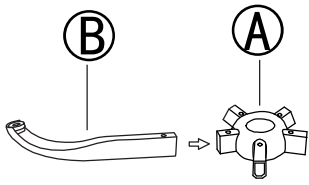
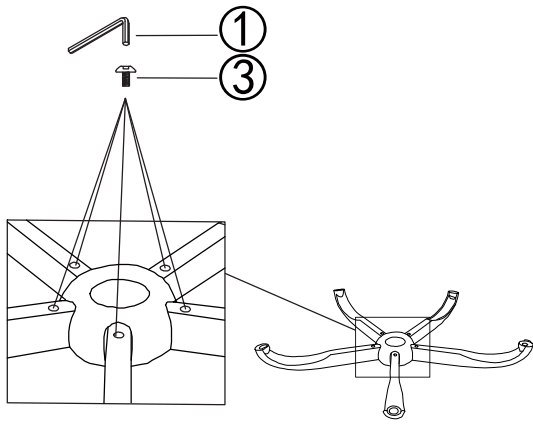
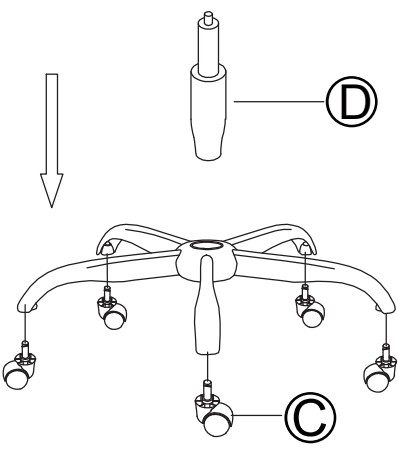
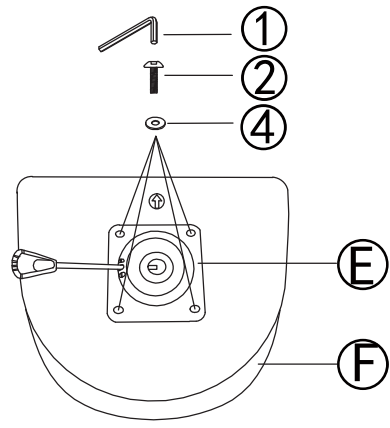
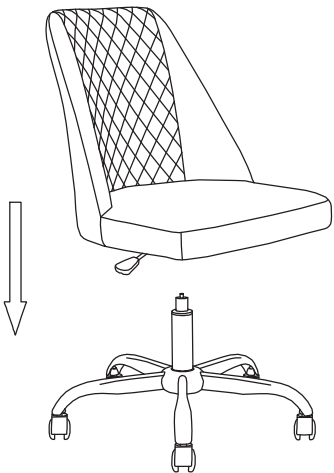
<p>STEP 1</p> 	<p>STEP 2</p> 
<p>STEP 3</p> 	<p>STEP 4</p> 
<p>STEP 5</p> 	

ITEM:881197

## ASSEMBLY INSTRUCTIONS

STEP 7

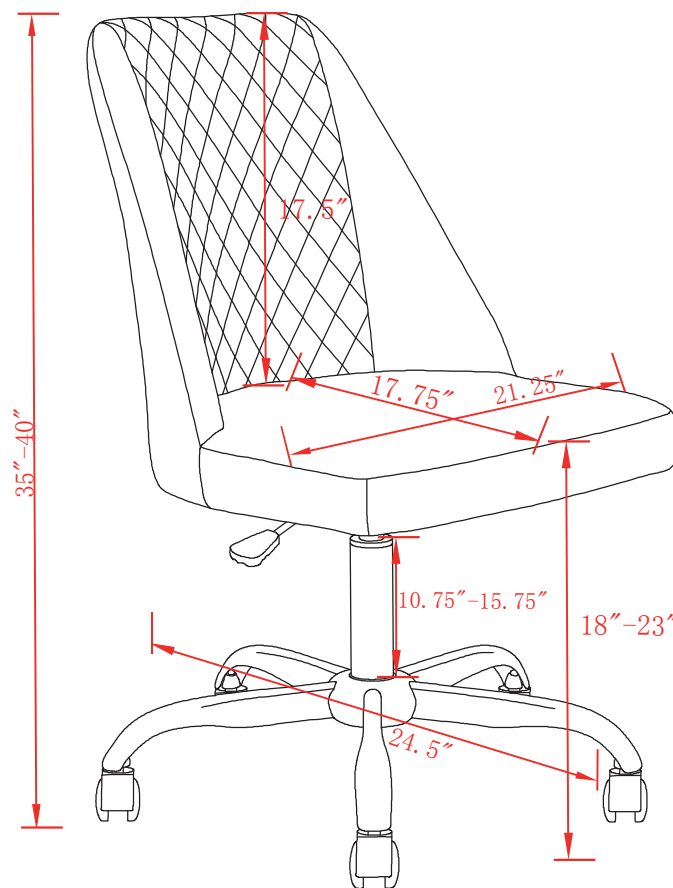

**Note :** Dimension tolerance  $\pm 5\%$