

ASSEMBLY INSTRUCTIONS
COASTER FINE FURNITURE



Fine Furniture for every stage of life

801319
OFFICE CHAIR

ITEM :801319



ASSEMBLY INSTRUCTIONS

ASSEMBLY TIPS:

- 1.Remove hardware from box and sort by size.
- 2.Please check to see that all hardware and parts are present prior to start of assembly.
- 3.Please follow attached instructions in the same sequence as numbered to assure fast & easy assembly.



WARNING !

- 1.Don't attempt to repair or modify parts that are broken or defective. Please contact the store immediately.
- 2.This product is for home ues only and not intended for commercial establishments.

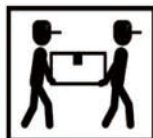

ASSEMBLY TIME 20 MINUTES

PARTS IDENTIFICATION

A		BACK	1PC
B		SEAT	1PC
C		LEFT ARM	1PC
D		RIGHT ARM	1PC
E		MECHANISM	1PC
F		GAS LIFT	1PC
G		BASE	1PC
H		CASTER	5PCS

HARDWARE IDENTIFICATION

1	SHORT SCREW	 M6*20mm	4PCS
2	LONG SCREW	 M6*25mm	6PCS
3	SMALL FLAT WASHER	 M6*14mm	6PCS
4	LARGE FLAT WASHER	 M6*18mm	8PCS
5	ALLEN KEY	 M6	1PC
6	LONGER SCREW	 M6*30mm	4PCS

ITEM:801319



ASSEMBLY INSTRUCTIONS

STEP1

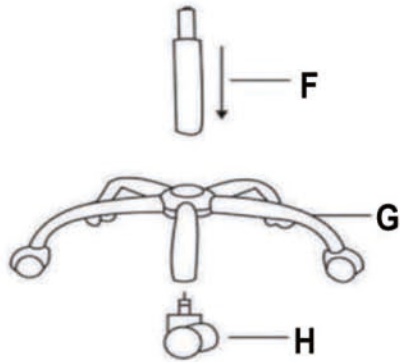

STEP2

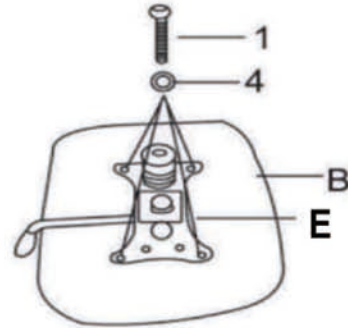

STEP3

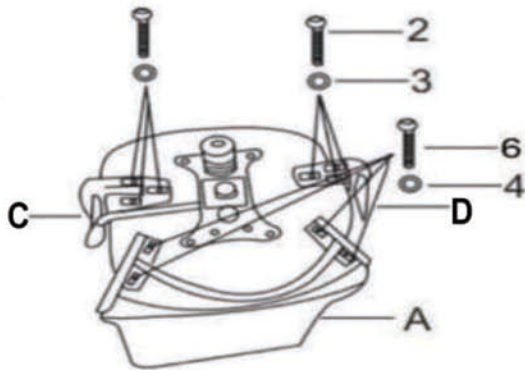

STEP4

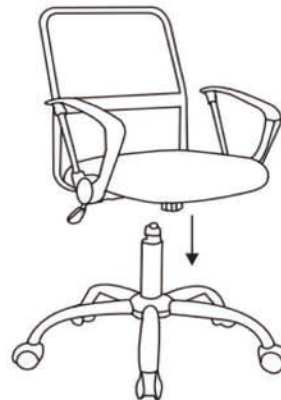

STEP5

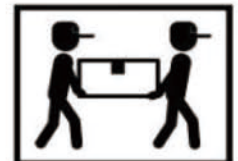

ITEM: 801319



Note : Dimension tolerance $\pm 5\%$