

Hartford Table Assembly Instructions

Required Tools:

- 1/2" Socket and Ratchet

Step 1 - First, Remove all nuts & washers from threaded bolts that extrude from legs

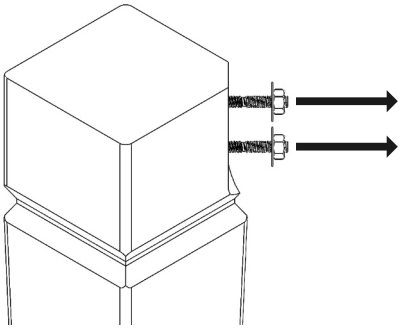

Step 2 - Lay the table top upside down on a soft surface free of any dirt or debris that could compromise the table top surface.

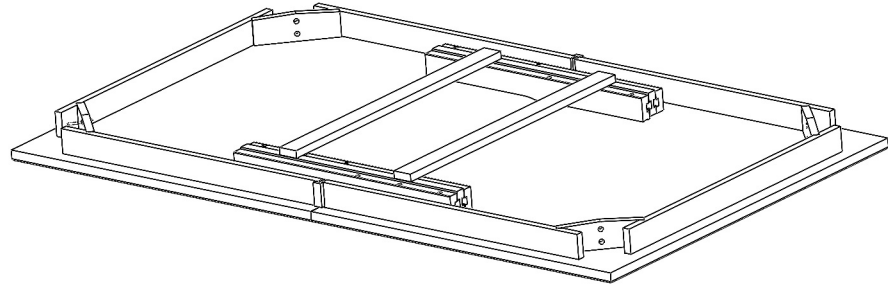

Step 3 - Slide the legs' threaded hanger bolts into the corner blocks. Insert washer and nuts and tighten until snug. **DO NOT OVER-TIGHTEN**

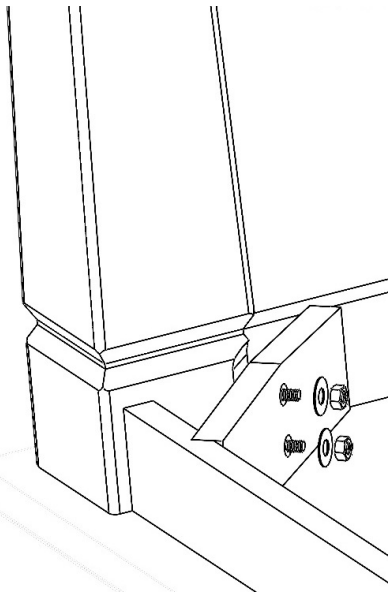

Step 4 - Flip the table over making sure to not put full weight on the legs when it is at an angle.

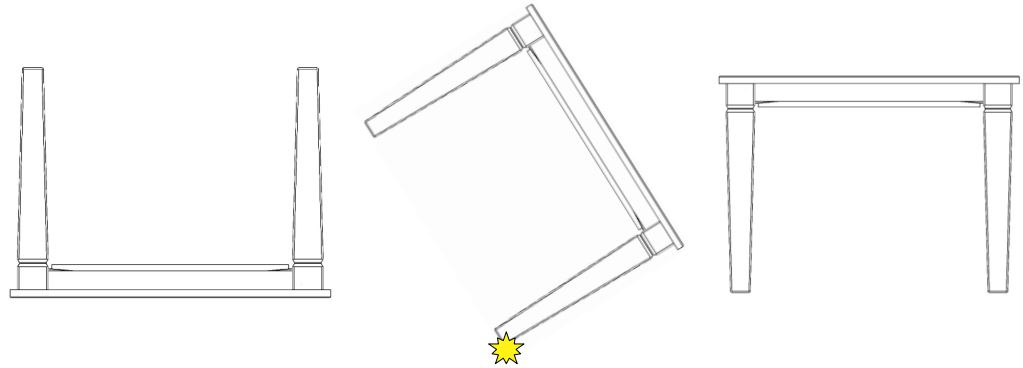

DO NOT REST FULL WEIGHT OF TABLE ON THE LEGS WHEN IN THIS POSITION