

# **CNT51**

## **CONTEMPO WORK SMART® SIT-TO-STAND DESK**

\*PATENT PENDING

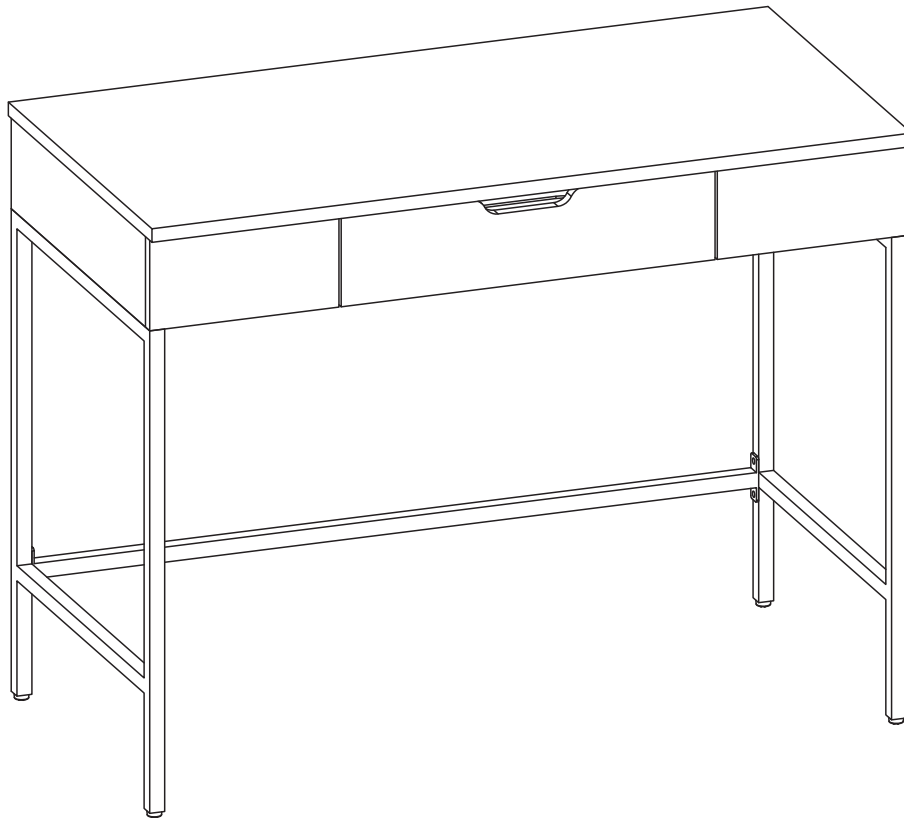

### **Assembly Instructions - Important:**

Carefully unpack and identify each component before attempting to assemble. Refer to parts list. Please take care when assembling the unit and always set the parts on a clean, soft surface. If you require any assistance with assembly, parts or information on other products, please visit our website: [www.officestar.net](http://www.officestar.net) or call or write us.



**STOP:** Read these instructions carefully and keep with the product for future reference. If this product is passed on to a third party, then these instructions must be included.

When using this product, basic safety precautions should always be followed to reduce the risk of injury including the following:

- A competent adult must assemble this product
- Keep children and pets away while assembling this product
- Do not let children climb or play on this product
- Children should not operate this lift mechanism
- Use caution when operating lift mechanism. To avoid possible pinching injury, keep hands clear of any contact zones
- Do not use this product if any parts are missing, damaged, or worn.
- To avoid scratching the floor, or product surface, assemble this product on a soft non marring surface.
- Always use this product on firm, level ground
- Regularly inspect the product for wear and tear. Stop using the product at first sign of damage or if parts become detached.
- Do not stand or sit on this product
- The lifted desktop payload is intended to hold up to 25 lbs (11.3 kg)
- The lift mechanism and all its moving parts must be replaced and/or repaired by a qualified professional.
- This product has been designed to operate only under its intended purpose.

## TO OPERATE LIFT DESK

\*Once desk assembly is complete, carefully inspect desk to insure all parts are operating correctly\*

### To Raise Desktop To 3-Level Sit To Stand Positions:

1. *With two hands, grasp front edge of desk top and using a steady even motion, pull desk top upward toward yourself until you hear an audible click to lock into desired position.*
2. *NOTE: You will hear an audible click to signify level option is locked into place.*
3. *The level options are: 1) All the way down with desk return  
2) Mid-level  
3) Standing height*

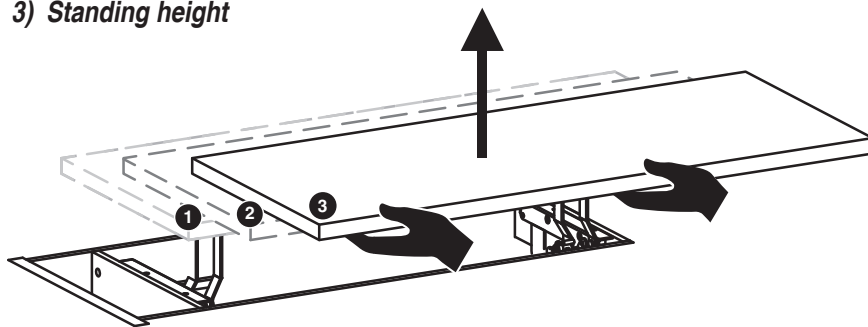

### To Lower Desk Lift Mechanism:

1. *With two hands, raise desk top to the highest (3rd) position. Gently push the desktop downward using a steady even motion. You will NOT hear any audible clicking when lowering mechanism is engaged.*
- NOTE: Our patent pending safety soft-close will pause just above the fully lowered position to prevent slamming. Firmly push downward to complete closure.*

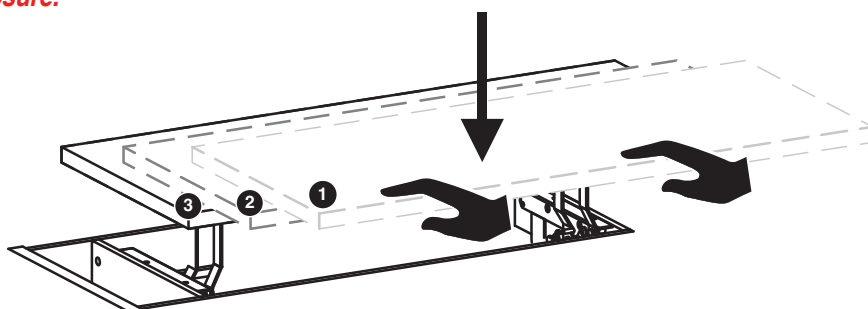

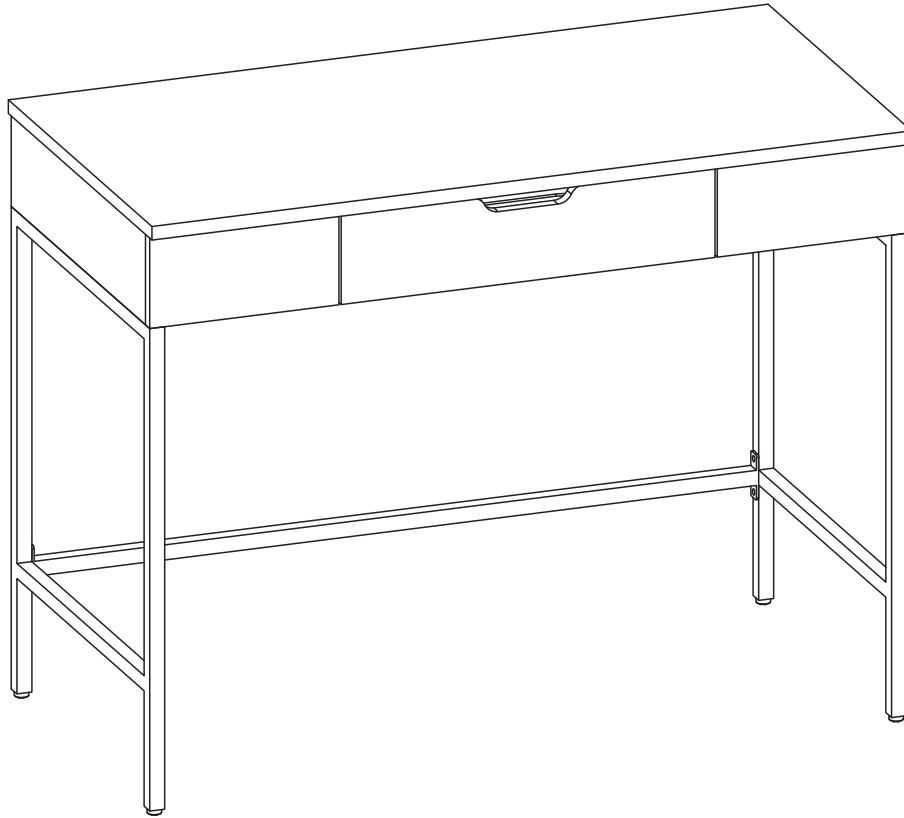

1. Do not use this product unless all screws and bolts are securely tightened.
2. Check that all screws and bolts are tight every three months or as needed.
3. Dispose of packing material properly. Do not use plastic cover as head covering. It may cause suffocation.
4. Do not use this product as a stepladder.
5. Use this product for its intended purpose only.
6. **FOR INDOOR RESIDENTIAL USE ONLY.**

#### **LIMITED WARRANTY**

OSP Home Furnishings® warrants to the original purchaser that this product will be free from defects in material and workmanship as described below. OSP Home Furnishings® will repair or replace, at its option, without charge to the original purchaser only, defective products or parts for one (1) year from the date of purchase. Replacement parts can only be supplied if parts are available. Items out of production may be unavailable. This warranty shall be effective for the applicable time period beginning from the date of purchase as shown on your original sales receipt. This warranty is your sole remedy for product defects and excludes defects due to or arising in connection with product abuse or misuse, use modification of, or attachments to the product, and products or parts not used, maintained, or installed in accordance with the company's installation, maintenance and/or applicable guidelines. There are no other warranties, express or implied, other than those specifically described, including without limitation any implied warranty of merchantability or of fitness for a particular purpose. OSP Home Furnishings® will not be responsible for incidental or consequential damages. Some states do not allow the exclusion or limitation of incidental or consequential damages, so the above limitations or exclusions may not apply to you. This warranty gives you specific legal rights and you may also have other rights which may vary from state to state. Our quality standards are among the highest in the industry. Sometimes, no matter how hard we try, there are times when parts are damaged or missing. Our Parts Department will do everything possible to promptly remedy the problem. Contact us via e-mail [parts@officestar.net](mailto:parts@officestar.net), by Fax 1-909-930-5629, or toll free parts number 1-800-950-7262, Monday through Friday 8:00 a.m. - 3:30 p.m. Pacific Time. To make a warranty claim, contact Parts Department. Provide model number, proof of purchase, description of the problem and obtain return authorization. At its option OSP Home Furnishings® will: (a) Supply compatible components of current manufacture. (b) Repair the customer's component. The customer must prepay freight on any components returned to the factory. Return freight on components still in warranty will be paid by OSP Home Furnishings®.

# PARTS

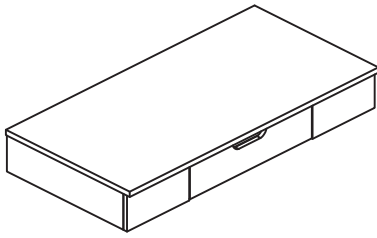

(A) Desk Top (1 PC)

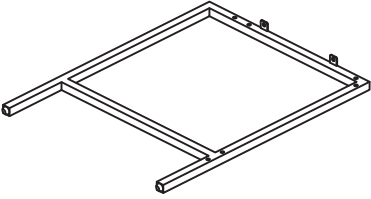

(B) Left Frame (1 PC)

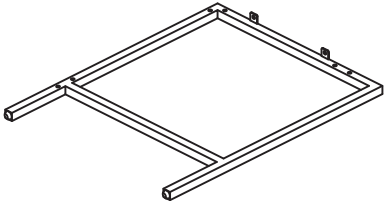

(C) Right Frame (1 PC)

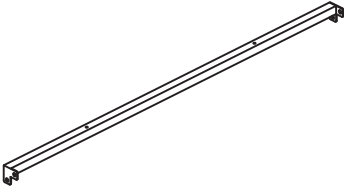

(D) Rear Upper Frame (1 PC)

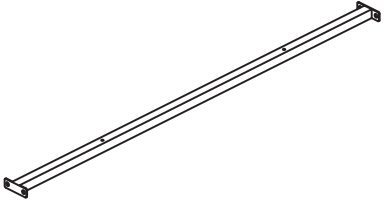

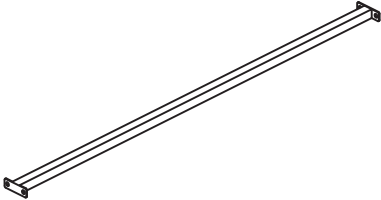

(E) Front Upper Frame (1 PC)

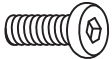

(F) Lower Support (1 PC)

# HARDWARE LIST

NO	DRAWING	DESCRIPTION	SIZE	QUANTITY
1		Bolt	1/4" x 1/2"	16 PCS + 2 Extra
2		Wood Screw	#8 x 1-1/4"	4 PCS
3		Allen Wrench	N/A	1 PC

Phillips screwdriver also needed for assembly (not provided)

# STEP 1

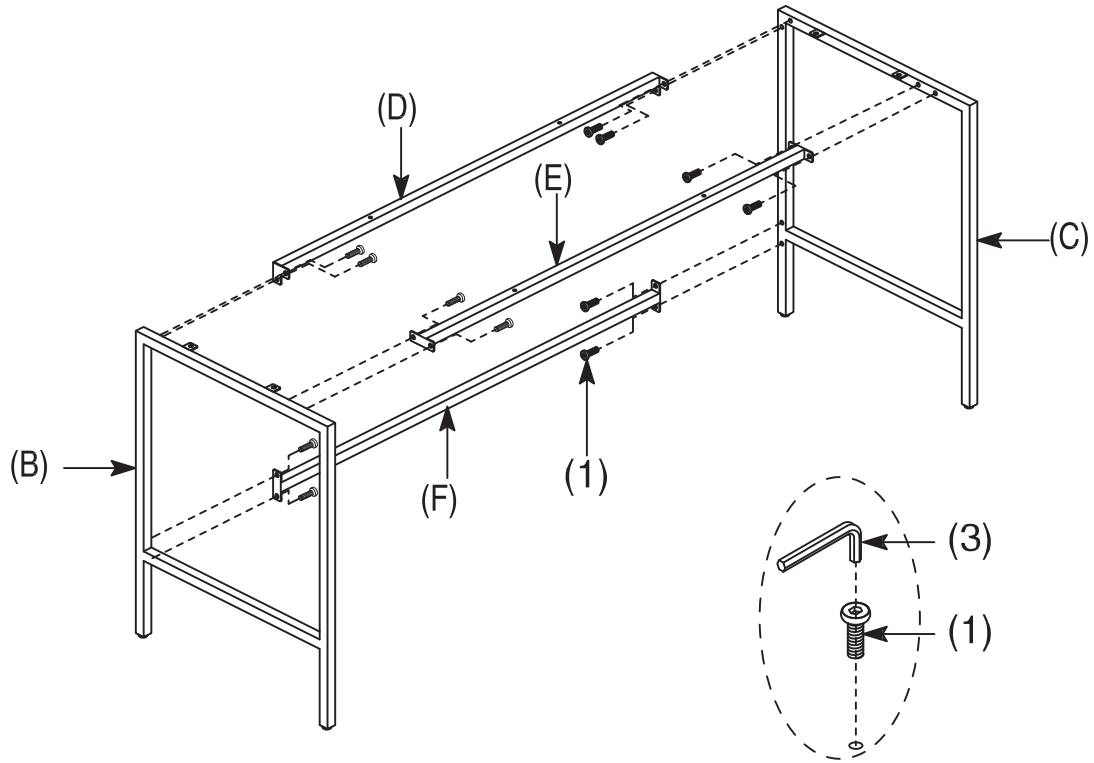

FULLY TIGHTEN ALL BOLTS

# STEP 2

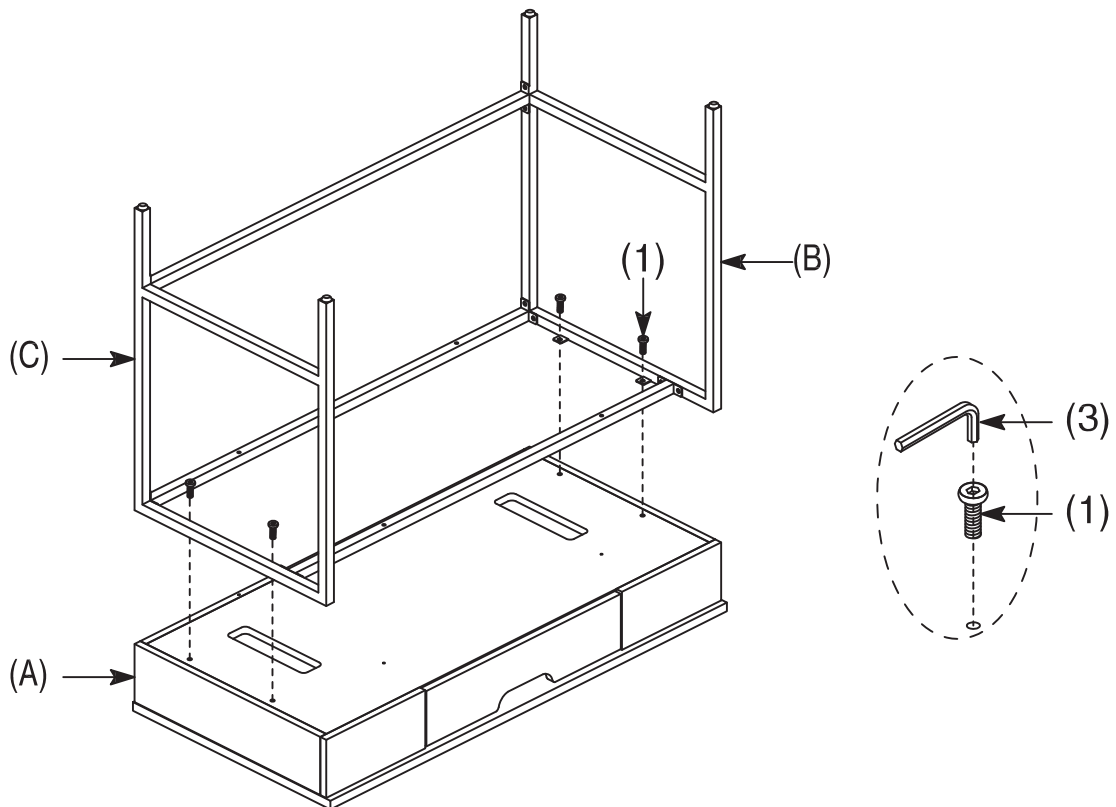

FULLY TIGHTEN ALL BOLTS

## STEP 3

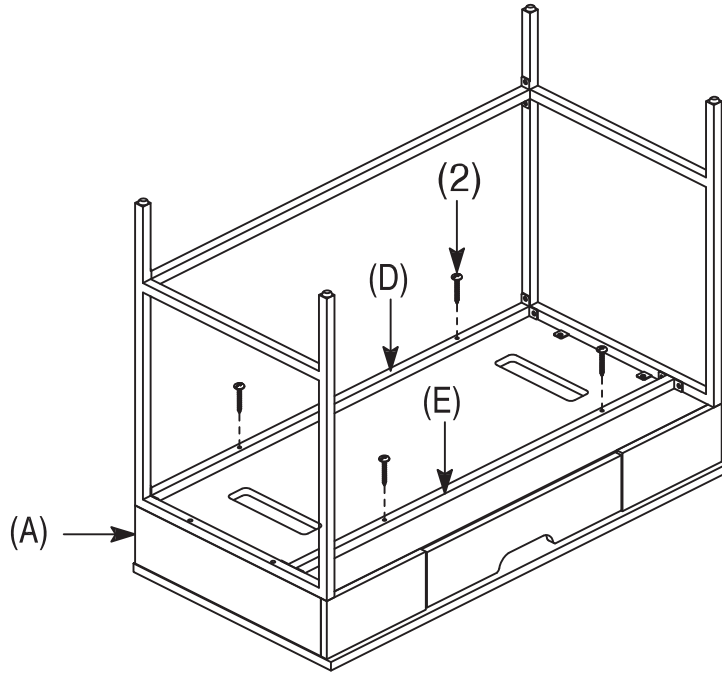

FULLY TIGHTEN ALL SCREWS

## STEP 4

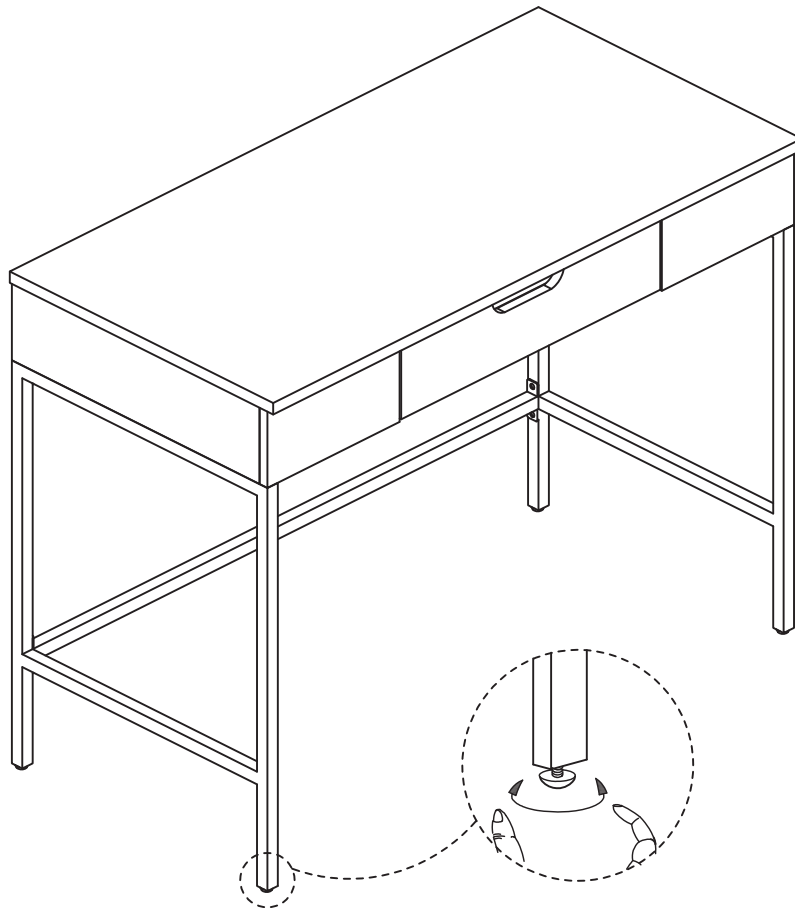

IF NEEDED, ADJUST LEVELERS TO LEVEL DESK