

ASSEMBLY INSTRUCTIONS
COASTER FINE FURNITURE



Fine Furniture for every stage of life

106591
Dining Table

REVISION 0: 11/18/2015
REVISION 1: 08/02/2016
REVISION 2: 12/01/2017
REVISION 3: 07/13/2020

ITEM: **106591**



ASSEMBLY INSTRUCTIONS

ASSEMBLY TIPS :

1. Remove hardware from box and sort by size.
2. Please check to see that all hardware and parts are present prior to start of assembly.
3. Please follow attached instructions in the same sequence as numbered to assure fast & easy assembly.



WARNING !

1. Don't attempt to repair or modify parts that are broken or defective. Please contact the store immediately.
2. This product is for home use only and not intended for commercial establishments.

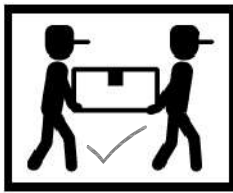

ASSEMBLY TIME

15 MINUTES

PARTS IDENTIFICATION

AN

TOP

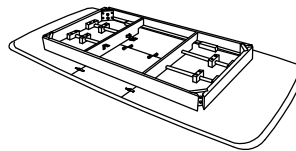

1PC

BN

LEG



4PCS

HARDWARE IDENTIFICATION

1

ALLEN WRENCH
(M5 x 65mm - BLK)



1PC

2

BOLT
(M8 x 80mm - RBW)

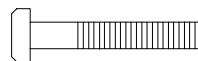

8PCS

3

LOCK WASHER
(5/16" - RBW)



8PCS

4

FLAT WASHER
(5/16" - RBW)



8PCS

NOTE :

Phillips head screw driver is required in the assembly process ; However, manufacturer not provide this item.

ITEM: **106591**

ASSEMBLY INSTRUCTIONS



STEP 1

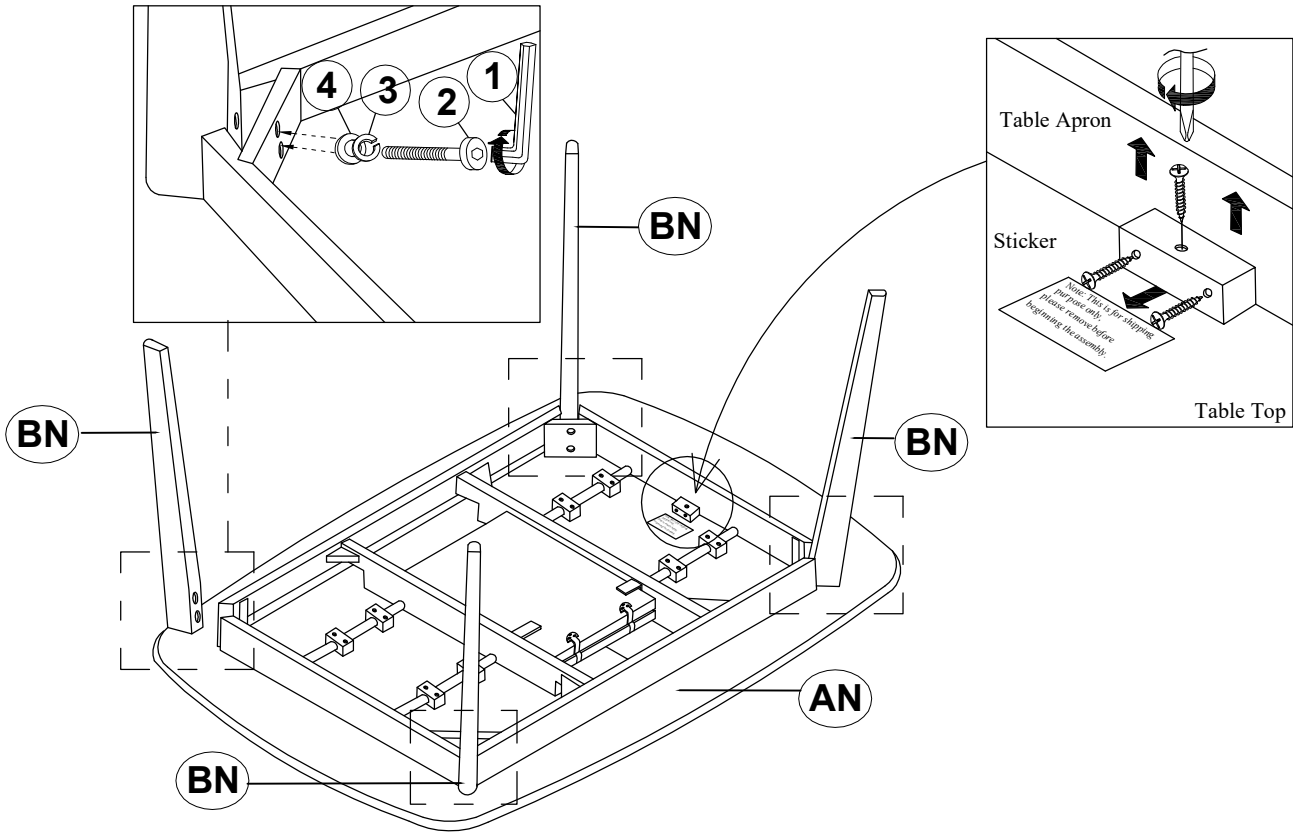

STEP 2

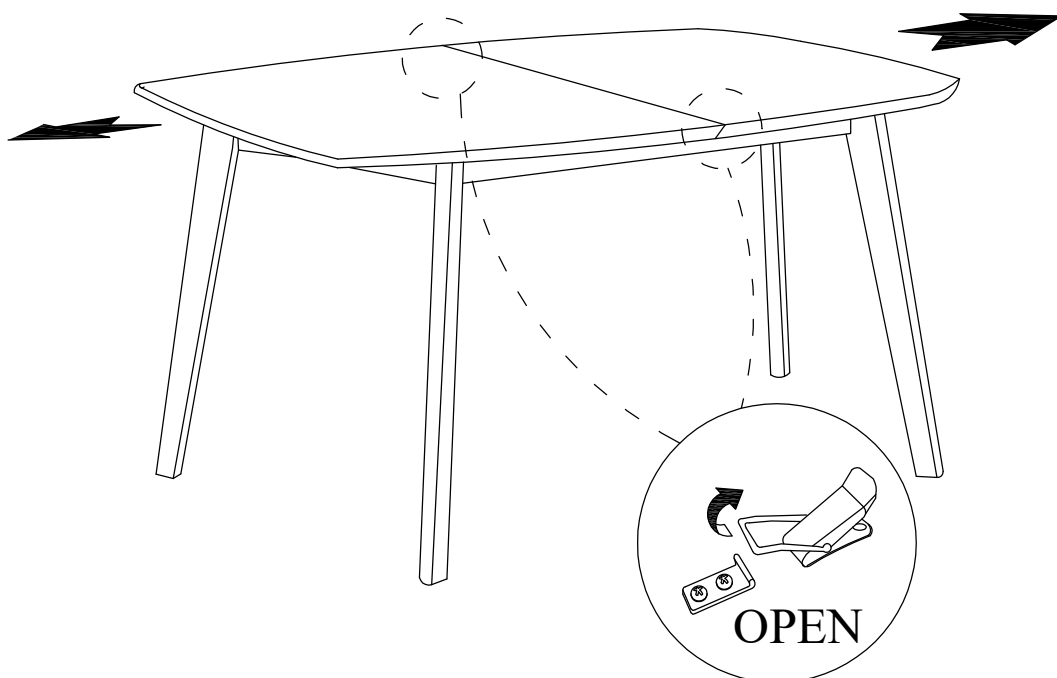

ITEM: **106591**

ASSEMBLY INSTRUCTIONS



STEP 3

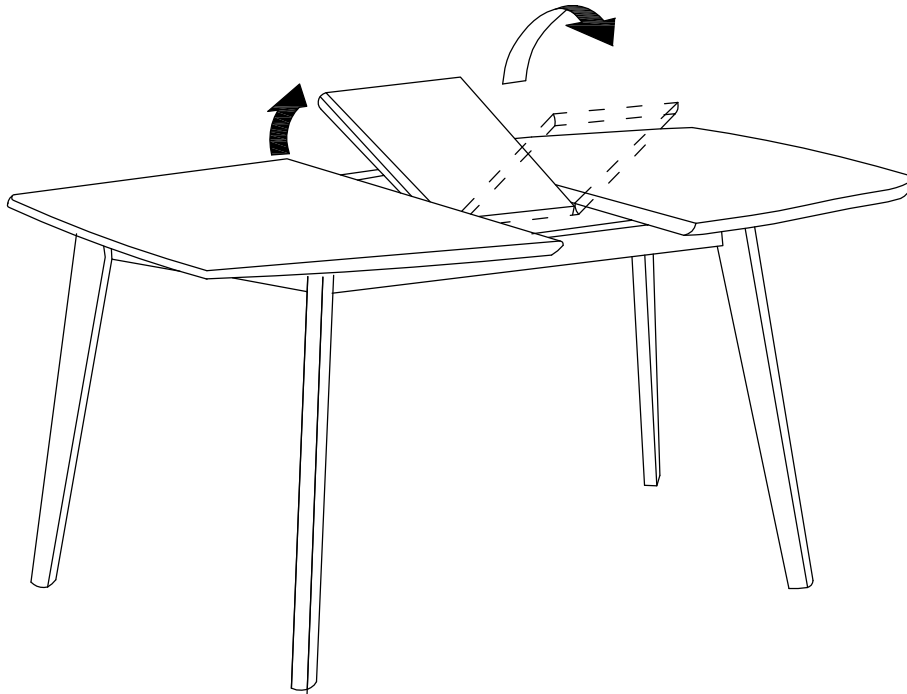

STEP 4

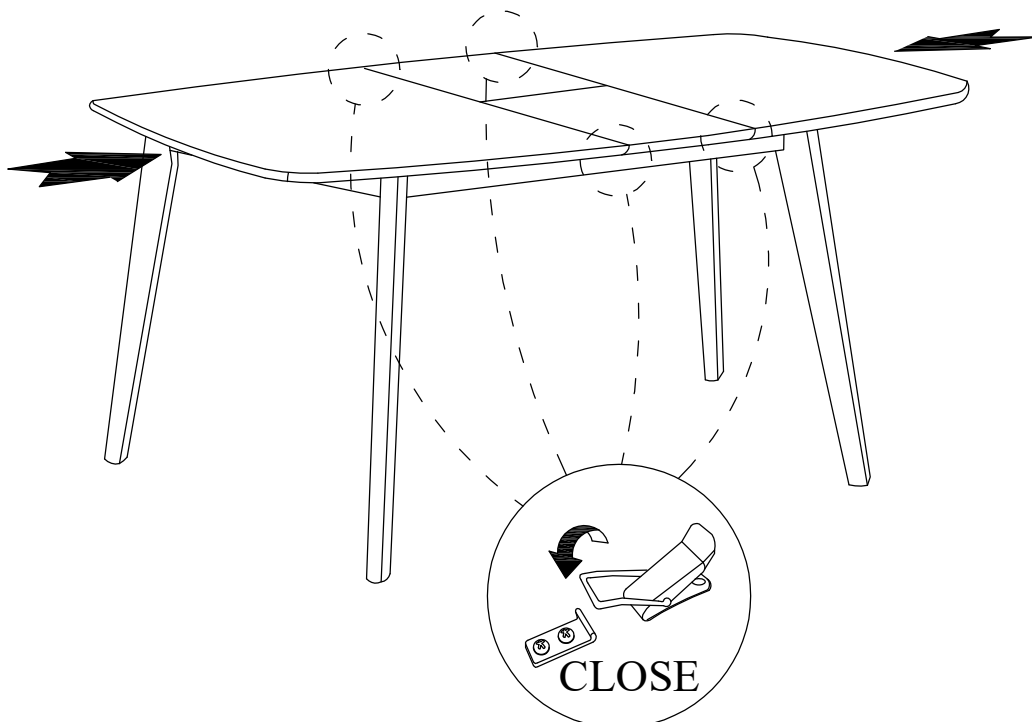

ITEM: **106591**
ASSEMBLY INSTRUCTIONS



STEP 5
COMPLETE

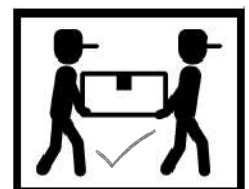
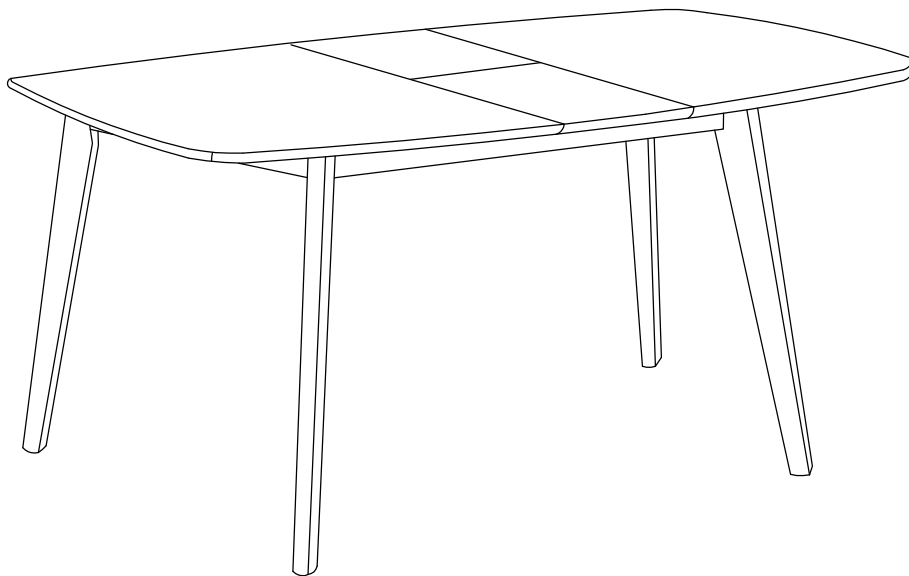

ITEM: 106591

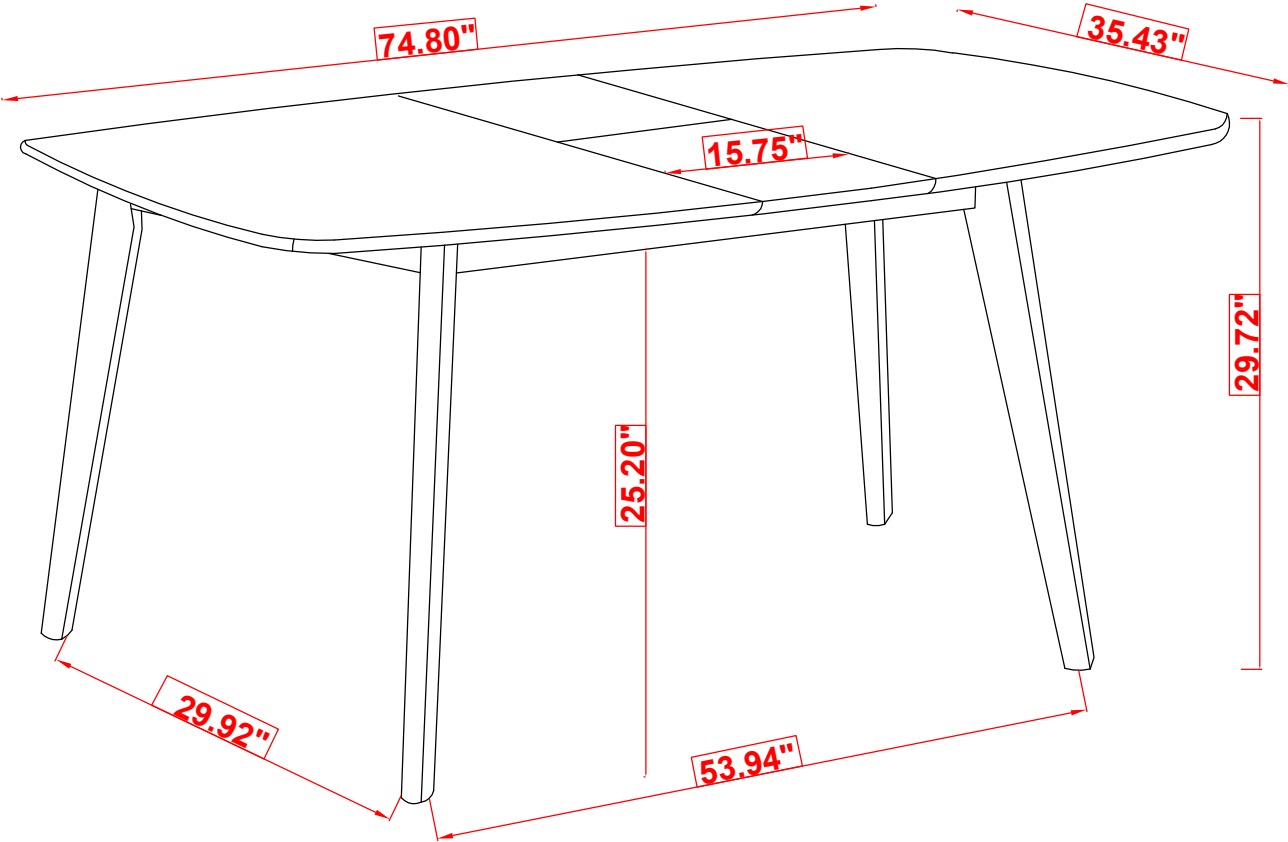

Note : Dimension tolerance $\pm 5\%$