

*ASSEMBLY INSTRUCTIONS*  
*COASTER FINE FURNITURE*



*Fine Furniture for every stage of life*

**720747**  
**END TABLE**

REVISION 0 : 09/22/2017  
REVISION 1 : 07/29/2019

ITEM: 720747



# ASSEMBLY INSTRUCTIONS

## ASSEMBLY TIPS:

1. Remove hardware from box and sort by size.
2. Please check to see that all hardware and parts are present prior to start of assembly.
3. Please follow attached instructions in the same sequence as numbered to assure fast & easy assembly.



### WARNING!

1. Don't attempt to repair or modify parts that are broken or defective. Please contact the store immediately.
2. This product is for home use only and not intended for commercial establishments.

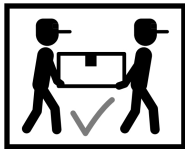

ASSEMBLY TIME 40 MINUTES

## PARTS IDENTIFICATION

A	TOP GLASS		1PC
B	SHELF GLASS		1PC
C	TOP FRAME		1PC
D	BOTTOM FRAME		1PC
E	SUPPORT BAR		4PCS

## HARDWARE IDENTIFICATION

1	BOLT (1/4" x 15mm SR)		4PCS	4	CAP (48mm BLK)		4PCS
2	LARGE SUCTION CUP (8mm)		4PCS	5	BULLET BOLT ( $\phi$ 14 x 9.5mm SR)		4PCS
3	SMALL SUCTION CUP ( $\phi$ 12mm)		4PCS	6	ALLEN WRENCH (4mm)		1PC

# ITEM: 720747 ASSEMBLY INSTRUCTIONS



**STEP 1** Do not tighten until each step is completed or instructed.

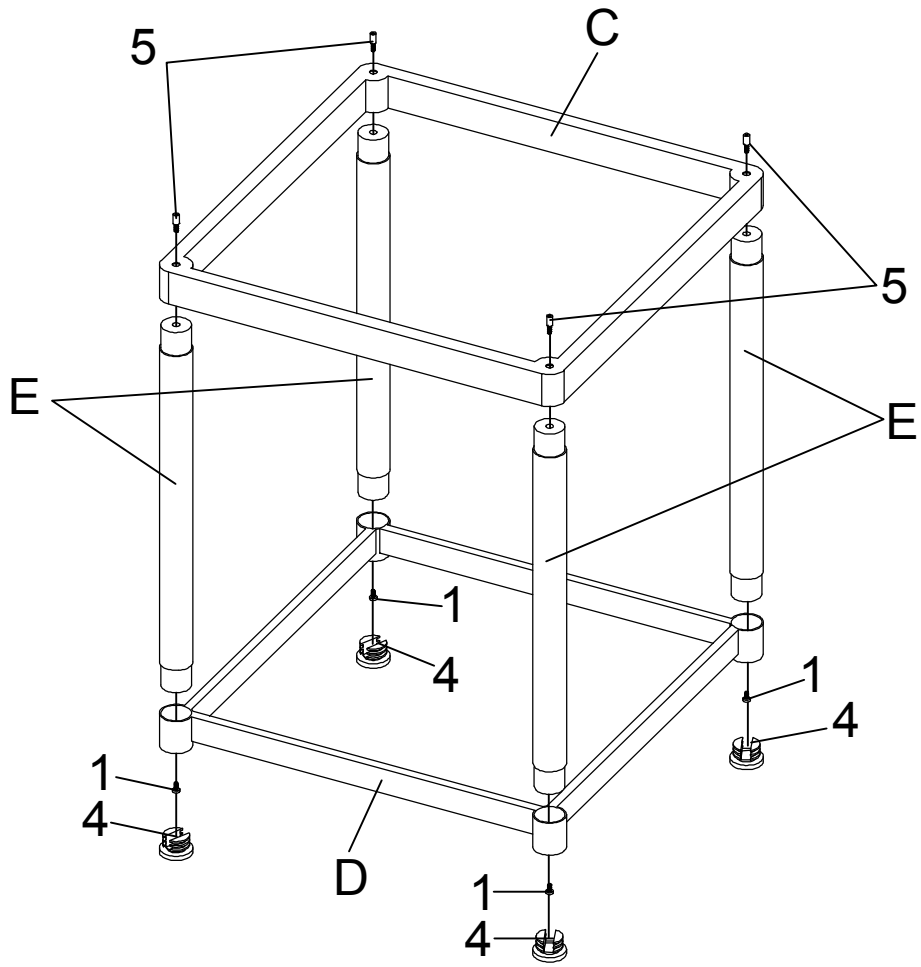

ITEM: 720747  
**ASSEMBLY INSTRUCTIONS**  
STEP 2

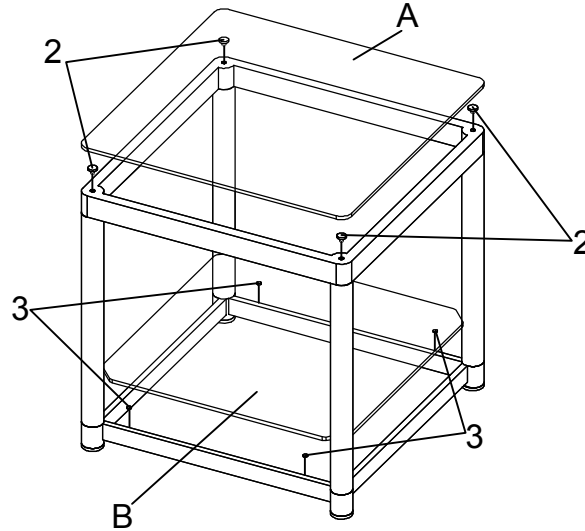

STEP 3  
**COMPLETE**

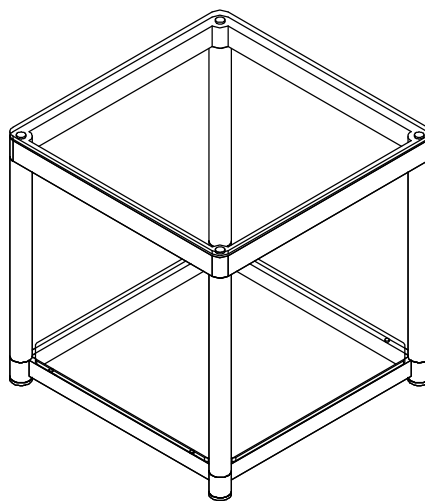

How to clean Acrylic product:  
Using a dry soft microfiber cloth, lightly brush off any dust.  
For additional care, dampen the cloth with warm water.  
For deepest cleaning, use an Acrylic cleaner.

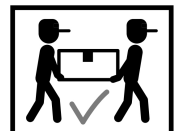

ITEM:

# ASSEMBLY INSTRUCTIONS



<b>Product Size :610 X 610 X 603 H (MM)</b>
<b>Product Size : 24" X 24" X 23 <math>\frac{3}{4}</math>"</b>

