

---

ASSEMBLY INSTRUCTIONS



ASSEMBLY INSTRUCTION

ASSEMBLY TIPS:

- 1.Remove hardware from box and sort by size.
- 2.Please check to see that all hardware and parts are present prior to start of assembly.
- 3.Please follow attached instructions in the same sequence as numbered to assure fast & easy assembly.



**Warning!!**

- 1.Don't attempt to repair or modify parts that are broken or defective. Please contact the store immediately.
- 2.This product is for home use only and not intended for commercial establishment.

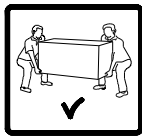



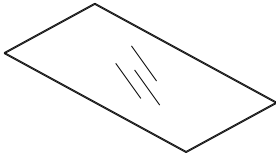
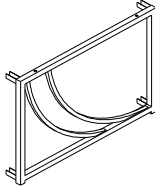
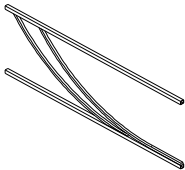

ASSEMBLY TIME PER UNIT: 40 MINUTES

PARTS IDENTIFICATION

<p><b>A</b></p> <p><b>TOP GLASS</b>  <b>1PC</b></p>	<p><b>B</b></p> <p><b>SIDE FRAME</b>  <b>2PCS</b></p>
<p><b>C</b></p> <p><b>FRONT AND BACK FRAME</b>  <b>2PCS</b></p>	

HARDWARE PACKAGE

Z	DESCRIPTION	FIGURE	Q'TY
1	BOLT (1/4"x12mm)		16PCS
2	SUCTION CUP (8mm)		4PCS
3	CAP (20x20mm)		4PCS
4	SMALL SUCTION CUP (φ 12mm)		2PCS
5	ALLEN WRENCH (4mm)		1PC

STEP 1

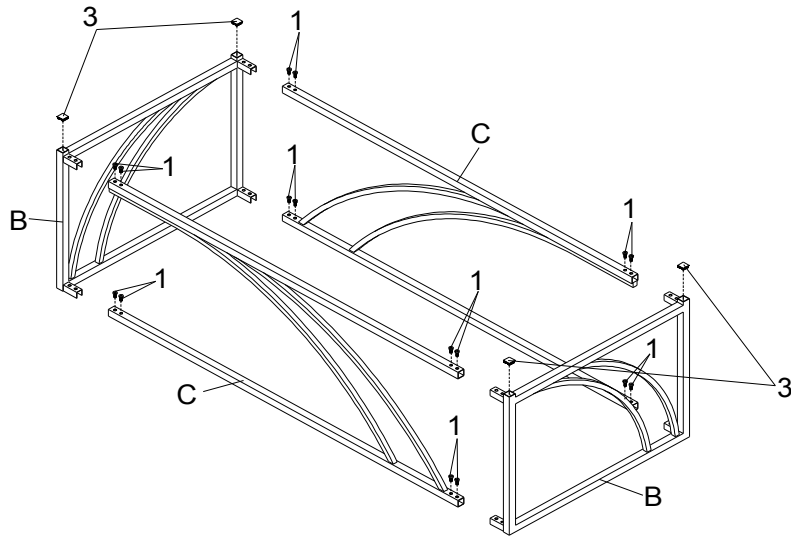

STEP 2

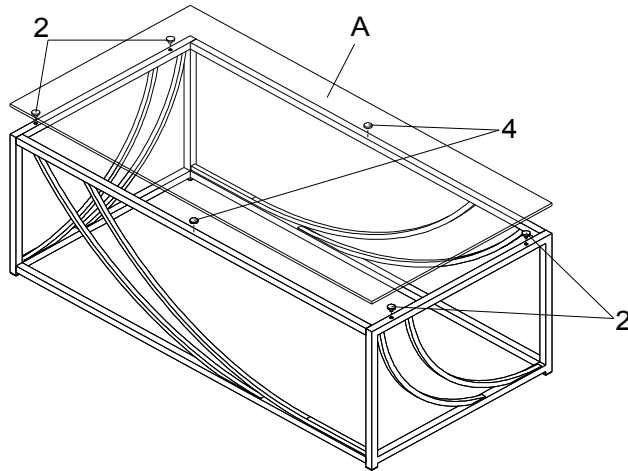

FINISH

