

ASSEMBLY INSTRUCTIONS
COASTER FINE FURNITURE



Fine Furniture for every stage of life

703737
END TABLE

REVISION 0 : 09/11/2017
REVISION 1 : 08/16/2019

ITEM: 703737



ASSEMBLY INSTRUCTIONS

ASSEMBLY TIPS:

1. Remove hardware from box and sort by size.
2. Please check to see that all hardware and parts are present prior to start of assembly.
3. Please follow attached instructions in the same sequence as numbered to assure fast & easy assembly.



WARNING!



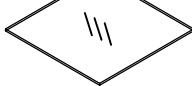
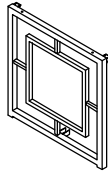
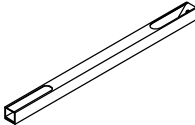
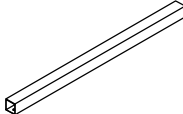

1. Don't attempt to repair or modify parts that are broken or defective. Please contact the store immediately.
2. This product is for home use only and not intended for commercial establishments.

ASSEMBLY TIME 25 MINUTES

PARTS IDENTIFICATION

A	TOP GLASS		1PC
B	SIDE FRAME		2PCS
C	TOP CROSSBAR		2PCS
D	BOTTOM CROSSBAR		1PC

HARDWARE IDENTIFICATION

1	BOLT (1/4" x 15mm SR)		8PCS	3	CAP (30 x 30mm)		4PCS
2	SUCTION CUP (9mm)		4PCS	4	ALLEN WRENCH (4mm)		1PC

ITEM: 703737 ASSEMBLY INSTRUCTIONS



STEP 1 Do not tighten until each step is completed or instructed.

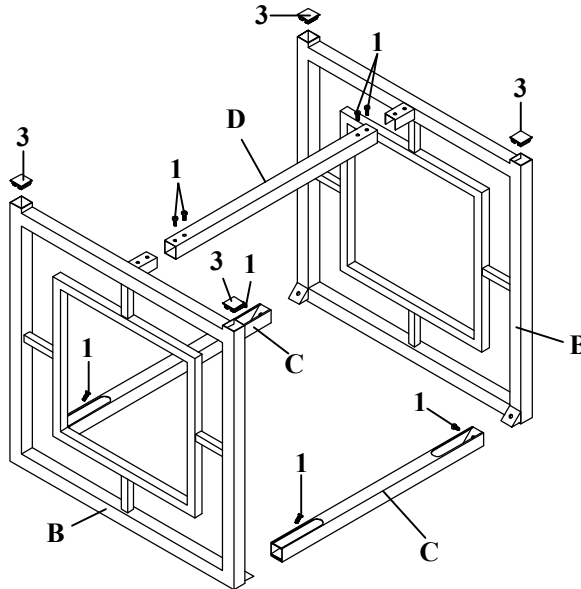

STEP 2

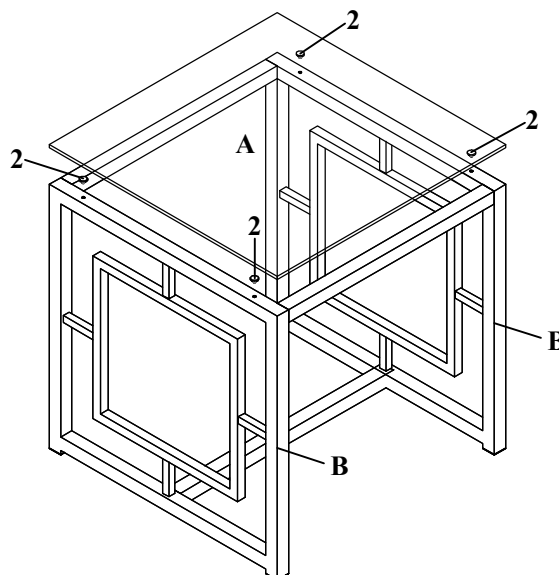

COMPLETE

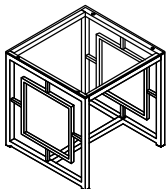

ITEM: 703737 ASSEMBLY INSTRUCTIONS



Product Size : 603 X 603 X 578 H (MM)

Product Size : 23 $\frac{3}{4}$ " X 23 $\frac{3}{4}$ " X 22 $\frac{3}{4}$ "

