



LIVING SPACES

ALOR KING/QUEEN PLATFORM

Assembly Instructions

PARTS LIST

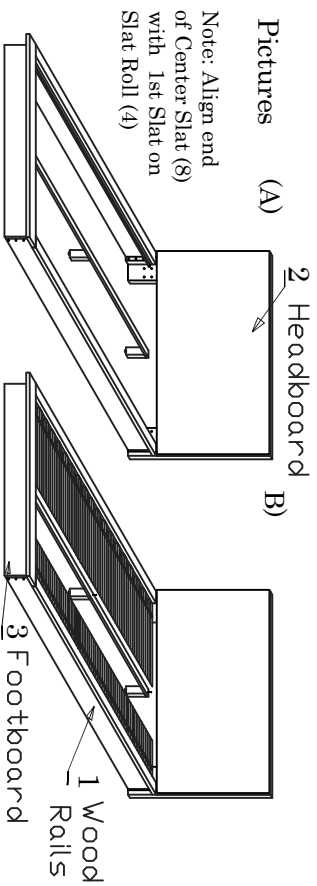

Note: Align end of Center Slat (8) with 1st Slat on Slat Roll (4)

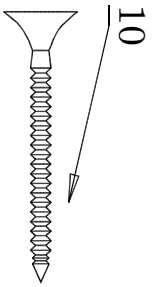
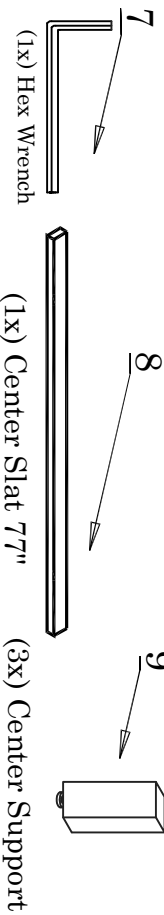
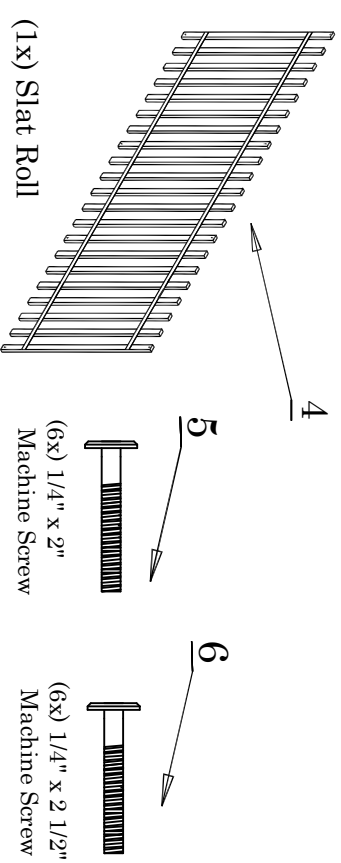

*Optional board for platform if Headboard is not used

Crossboard: Queen $1\frac{1}{16}'' \times 9\frac{1}{4}'' \times 68\frac{1}{2}''$
 King $1\frac{1}{16}'' \times 9\frac{1}{4}'' \times 85\frac{1}{4}''$
 Cal King $1\frac{1}{16}'' \times 9\frac{1}{4}'' \times 81\frac{1}{4}''$

Step 1

Attach Headboard (2) to Wood Rails (1) using (6x) $\frac{1}{4}'' \times 2\frac{1}{2}''$ Machine Screw (6) and Tighten the screws using the Hex Wrench (7).

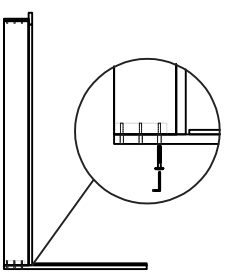

Step 2

Attach Footboard (3) to Wood Rails (1) using (6x) $\frac{1}{4}'' \times 2''$ Machine Screw (5) and Tighten the screws using the Hex Wrench (6).

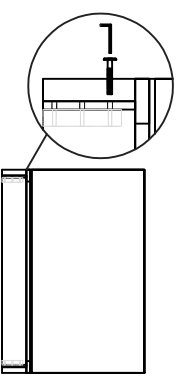

Step 3

Join Center Slat (8) with Center Supports (9) using (3x) $1\frac{5}{8}''$ Screws (10). Screw in Supports (9) to each edge of the Slat (8) and screw in the other Support (9) in the middle of slat, As seen in picture (A).

Step 4

Center slat(8) with Supports (9) should be placed under slat roll(4) and centered onto slat roll(4) as seen in picture (A). Attach Center Slat(8) to the slat roll (4) through predilled holes on the slat roll(4) using (3x) $1\frac{5}{8}''$ screws(10).

Step 5

Attach slat roll(4) to the Wood Rails (1) through predrill holes on the slat roll (4) using (4x) $1\frac{5}{8}''$ screws on each side (10). Make sure the slat roll is centered between Headboard (2) and Footboard (3).

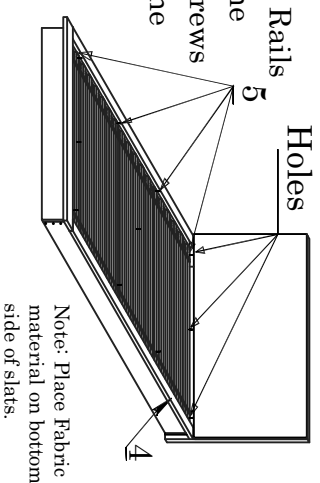

Note: If Headboard is not used in Platform, place optional board on back part of platform and assemble using (6x) $1\frac{1}{4}'' \times 2\frac{1}{2}''$ Machine Screws (6).