

ASSEMBLY INSTRUCTIONS

Description: Side Chair



Important safety instructions:

- Please carefully read all instructions before assembling the chair.
- For your safety and ease, assembly by two or more adults is recommended.
- Keep instructions for future use.



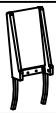

Pre-assembly:

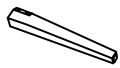
- Do not discard any contents until after assembly is complete to avoid accidentally discarding small parts or hardware.
- Remove all parts and hardware from box along with any plastic protective packaging.

Parts List

| Item | Description | QTY |
|------|--|-----|
| A | Chair Back  | 1 |
| B | Seat Cushion  | 1 |
| C | Front Legs  | 2 |

Hardware List

| Item | Description | QTY |
|------|---|-----|
| a | Long Bolts Ø5/16**2"  | 6 |
| b | Short Bolts Ø5/16**1-1/2"  | 2 |
| c | Lock Washers 5/16"  | 8 |
| d | Flat Washers 5/16"  | 8 |
| e | Allen Wrench 5/16"  | 1 |

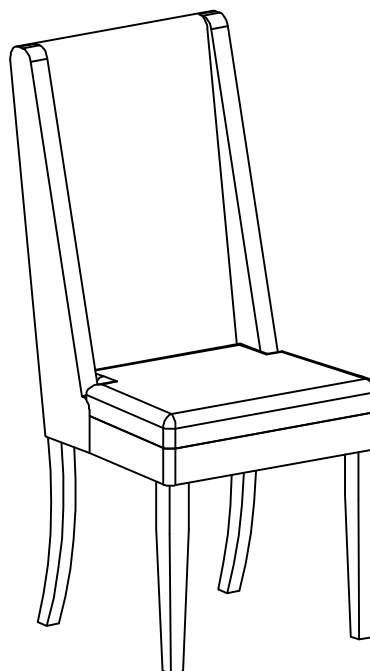

Assembly Procedures:

Step 1. Assemble the chair on a flat, soft surface such as a carpet or cloth to prevent scratching the finish. Attach the seat cushion (B) to chair back (A) using bolts (a), lock washers (c), flat washers (d). Loosely tighten by Allen wrench (e).

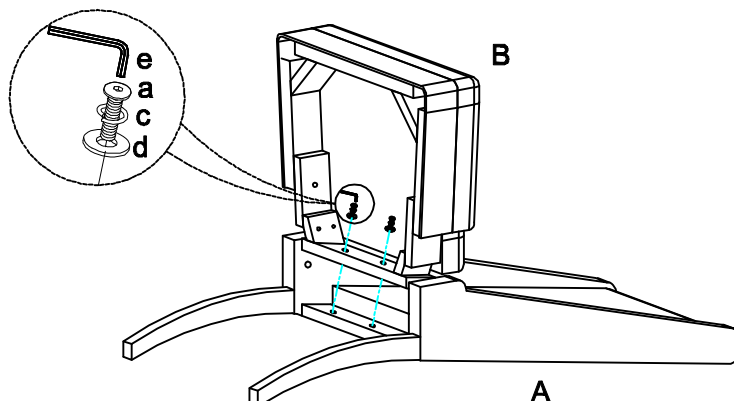

Step 2. Attach the seat cushion (B) to the leg of chair back (A) using bolts (b), lock washers (c) and flat washers (d). Loosely tighten with Allen wrench (e).

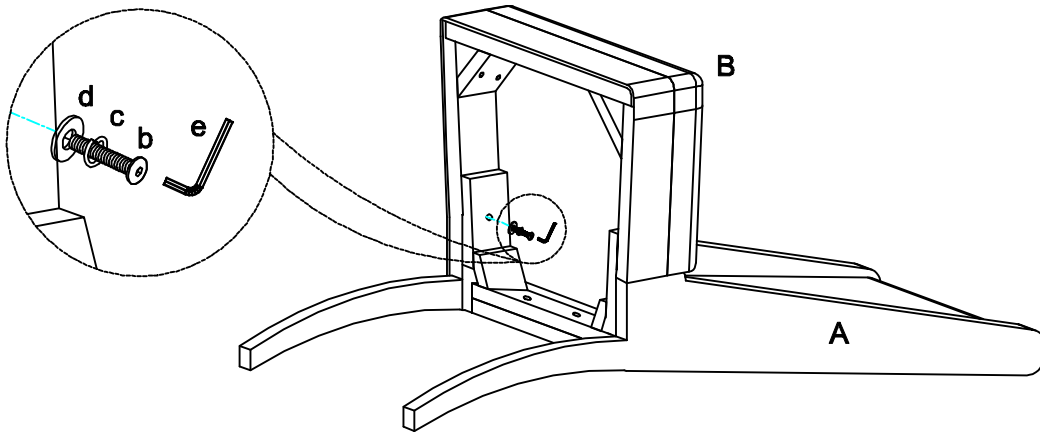

Step 3. Attach front legs (C) to seat cushion (B) using bolts (a), lock washers (c) and flat washers (d). Loosely tighten the bolts with Allen wrench (e).

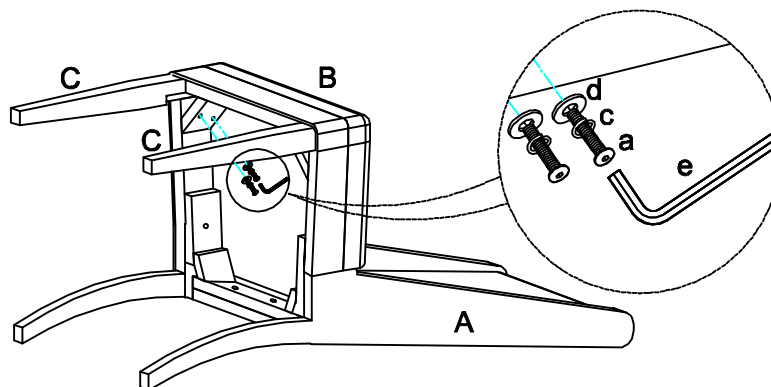

Step 4. Securely tighten all bolts with Allen wrench (e), but do not over tighten the bolts. Assembly is complete.

ADDITIONAL NOTE ABOUT SAFETY: BOLTS MAY LOOSEN DURING NORMAL EVERYDAY USE. THEY SHOULD BE PERIODICALLY INSPECTED AND RE-TIGHTENED TO PREVENT DAMAGE OR INJURY. ALWAYS CHECK TO BE SURE THAT ALL HARDWARE IS KEPT TIGHTENED.

Thank you for your purchase