



MIRAVAL OUTDOOR DAYBED

GB025A-W-1

267651/267652/267653

Assembly Instruction

Parts List:

REF	DESCRIPTION	IMAGE	QTY
A	LEFT SHEEL		1
B	RIGHT SHEEL		1
C	BASE		1
D	CUSHION		1
E	LARGE PILLOW		4
F	SMALL PILLOW		4

Hardware List:

REF	DESCRIPTION	IMAGE	QTY
019	BOLT (M6*20L)		2
024	BOLT (M6*45L)		9
005	WASHER (M6, ID Φ 6.5, OD Φ 16)		11
009	PLASTIC BOLT CAP (M6)		11
001	ALLEN WRENCH (M6)		1
049	ALUMINUM SHEET		1

Diagram:

Step 1

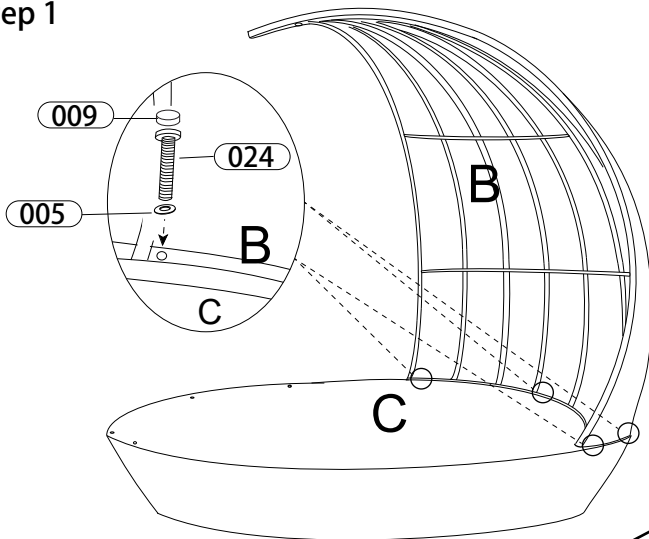

Step 2

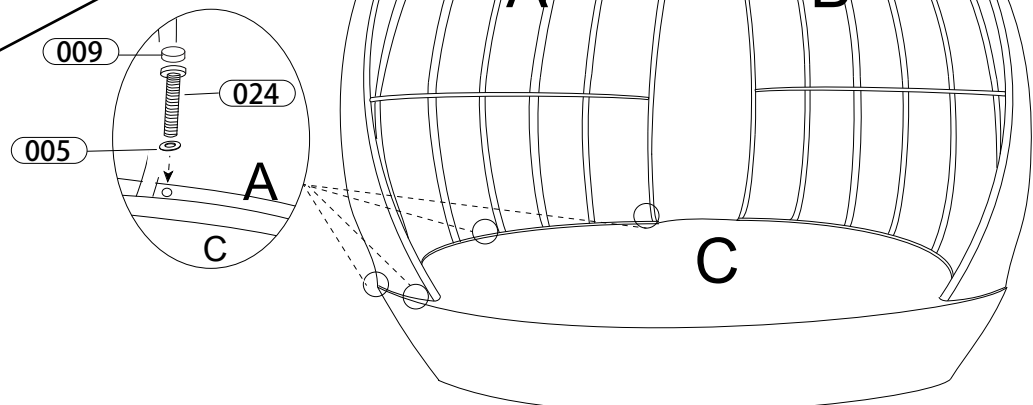

Step 3

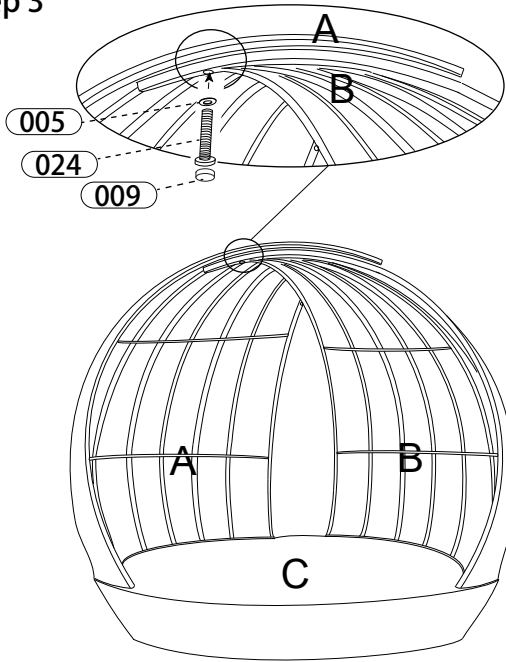

Step 4

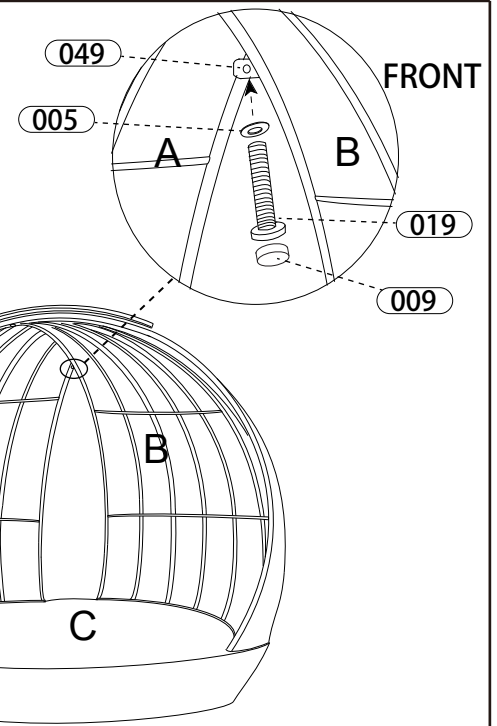

Step 5

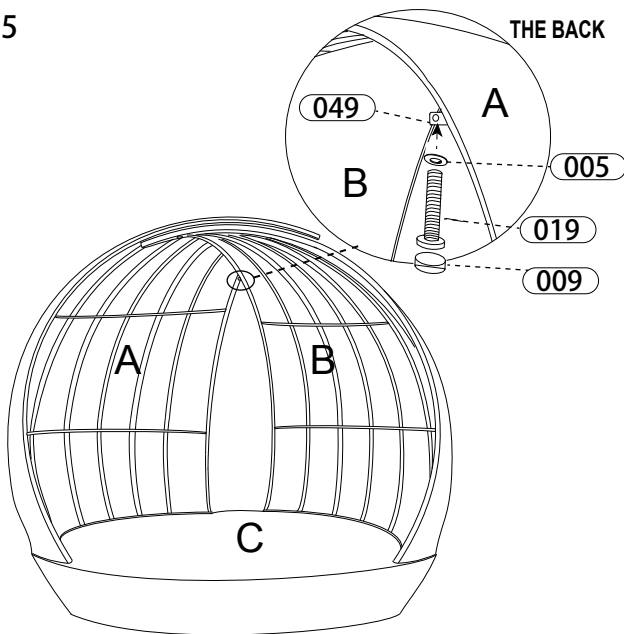

Step 6

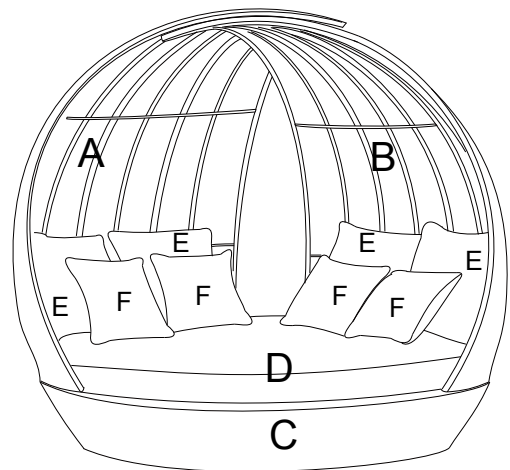

Assembly Steps:

Tip-Remove protective wrapping and lay all parts on floor. Make sure all parts packed in carton against attached parts list to make sure all parts are presented.

Step1:Align the right wheel (B) with the hole of the seat (C), use the spacer (005), screw (024) and pe cap (009) as shown in the figure.

Step2:Align the left wheel (A) with the hole of the seat (C), use the spacer (005), screw (024) and pe cap (009) as shown in the figure.

Step3:At the top joint of the left wheel (A) and the right wheel (B), use the spacer (005) screw (024) pe cap (009) as shown in the figure.

Step4:As shown in the figure, fix one end of the aluminum sheet (049) to the middle position of the left wheel (A) with washer (005), screw (019) and pe cap (009).

Step5:As shown in the figure, on the back of the product, fix the other end of the aluminum sheet (049) to the middle position of the right wheel(B) with washer (005), screw (019) and pe cap (009).

Step6:As shown in the figure,and place the cushion, back cushion on the sofa.

NOTE1: Do not fully tighten the bolts until the item is fully assembled.

NOTE2: It is user's responsibility to make sure all parts are assembled and tightened properly and securely.