

L I V I N G S P A C E S



ASSEMBLY INSTRUCTIONS

ITEM 305-P260230 CHAIR



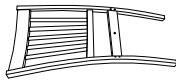
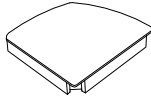

Thank you for purchasing this quality product. Be sure to check all packing material carefully for small hardware which may have come loose inside the carton during shipment. Identify and count all hardware and compare with the hardware list below.

When placing furniture on non-carpeted flooring, HMI recommends the use of floor protection such as an area rug or furniture pads. Area rugs and padding not included with purchase.

PARTS LIST

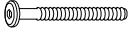
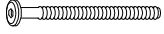
No.	Description	Sketch	Quantity
1	Chair Back		1
2	Chair Seat		1
3	Leg		2

HARDWARE LIST

No.	Description	Sketch	Quantity
A	JCBC M6 x 35mm		1
B	JCBC M6 x 60mm		4
C	JCBC M6 x 80mm		4
D	Spring Washer M6 x 13 ø		9
E	Flat Washer M6 x 19 ø		9
F	Allen Key M4 x 65mm		1

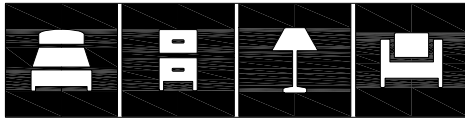

L I V I N G S P A C E S

ASSEMBLY INSTRUCTIONS

STEP 1

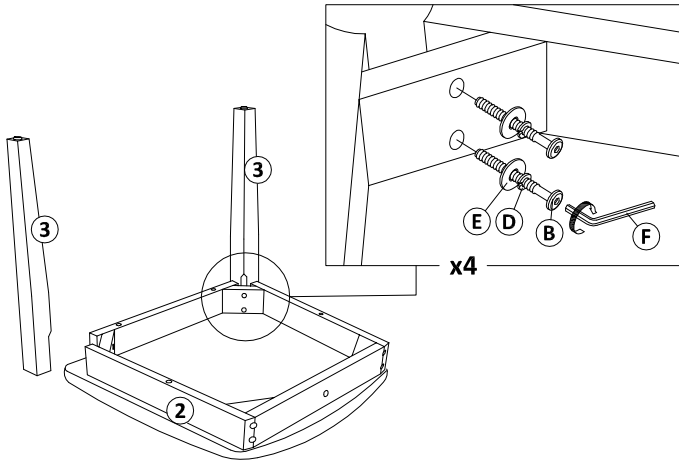

Attach Front leg(4) to Chair Seat (2).
Do not fully tighten on this step.

STEP 2

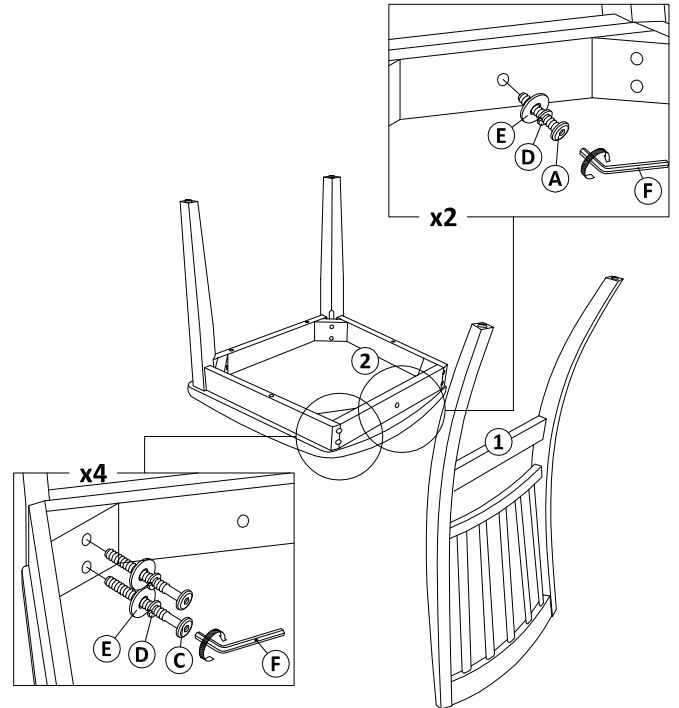

Attach Chair Back (1) to Chair Seat (2).
Do not fully tighten on this step.

COMPLETED

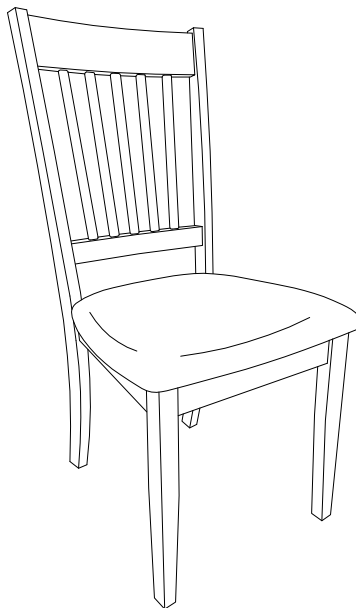

Turn the chair upright and place on level surface.
Adjust the front legs so that chair is level and does not wobble.
Tighten all the bolts and take care do not over tighten