



CAPRI OUTDOOR BAR CART
16BC076A-W-1
253550

Assembly Instruction

Parts List:

REF	DESCRIPTION	IMAGE	QTY
A	FRAME		1
B	HANDLE		2
C	SMALL TRAY		2
D	LARGE TRAY		1

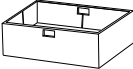
Hardware List:





REF	DESCRIPTION	IMAGE	QTY
019	BOLT (M6*20L)		4
005	WASHER (M6,IDΦ6.5,ODΦ16)		4
009	PLASTIC BOLT CAP (M6)		4
001	ALLEN WRENCH (M6)		1

Diagram:

Step 1



Step 2

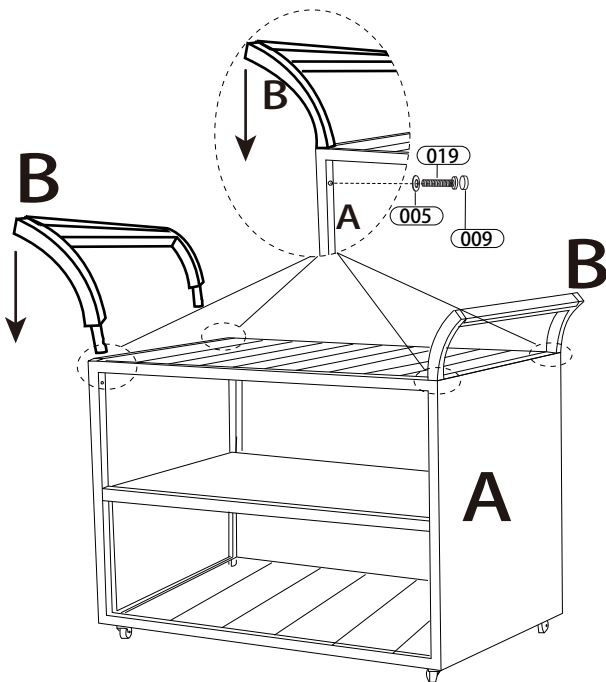
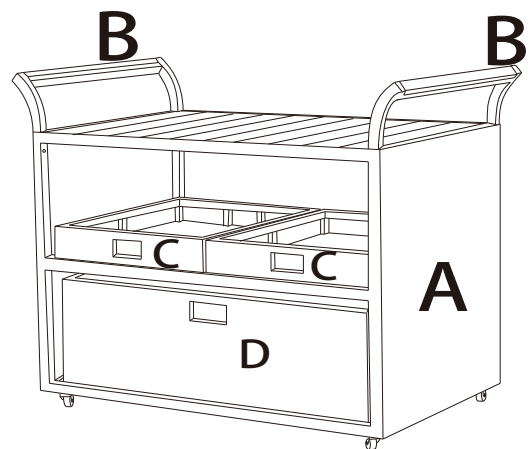

Assembly Steps:

Tip- Remove protective wrapping and lay all parts on floor. Identify all parts packed in Carton against attached parts list to make sure all parts are presented.

Step 1: Please put the one of handles(B) into the bolt holes simultaneously ,make sure they are aligned.Use the washer(005) and bolt(019) to lock the handle to dining car(A) with allen wrench(001),cover the plastic cap(009) over the bolt.The same procedures with the other handle.

Step 2: After installing the handle, place the large and small trays into the dining cart as shown.

NOTE: IT IS USER'S RESPONSIBILITY TO MAKE SURE ALL PARTS ARE ASSEMBLED AND TIGHTENED PROPERLY AND SECURELY.